

GeckoRacing

Ducati Hypermotard 620, 796, 1000, 1100 Evo, Multistrada

Lato freno - *Brake side*

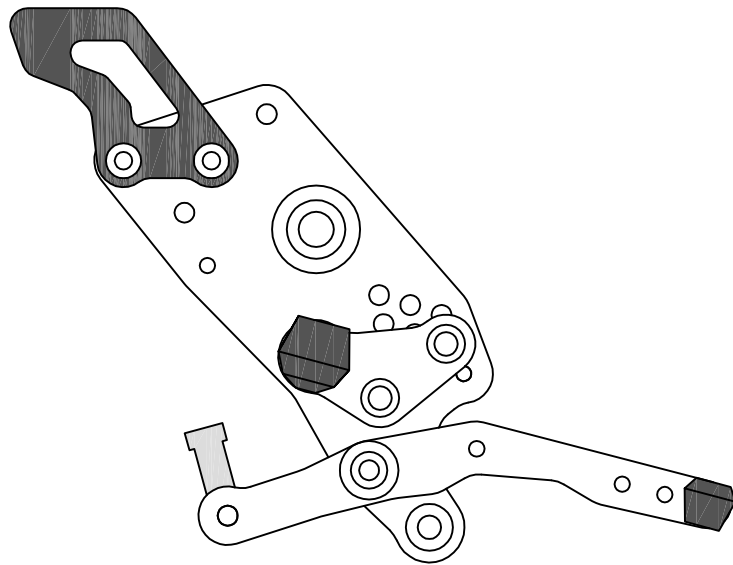

Lato cambio - *Gear side*

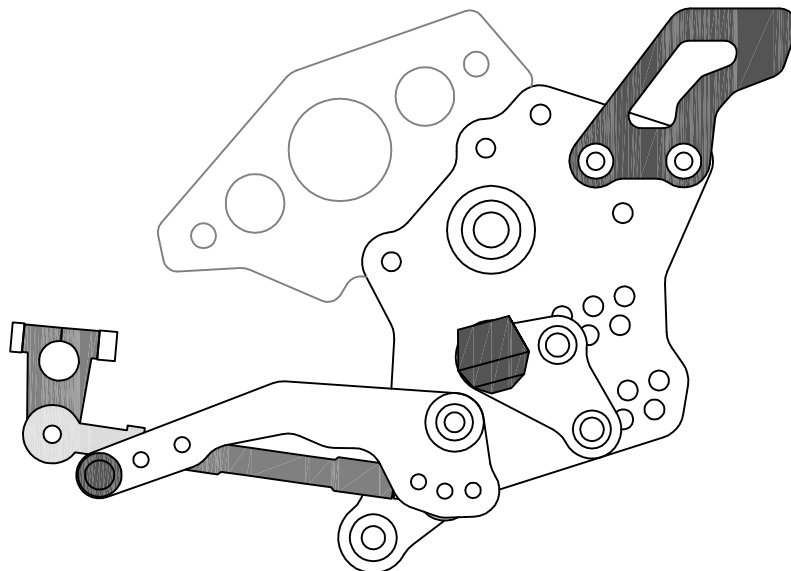

GeckoRacing

Ducati Hypermotard 620, 796, 1000, 1100 Evo, Multistrada

Bustina 1 - Bag 1 - (x2 con pedane passeggero | x2 with pillion pegs)
pedali poggiapiedi - footrest pegs



x2 + x2
bm8x16

Bustina 2 - Bag 2
pedalini leve - levers pedals



pedalino freno
brake lever pedal
x1 + x1
bm6x25

pedalino cambio
gear lever pedal
x1 + x1
bm6x40

Bustina 3 - Bag 3
paratacchi - heel guards

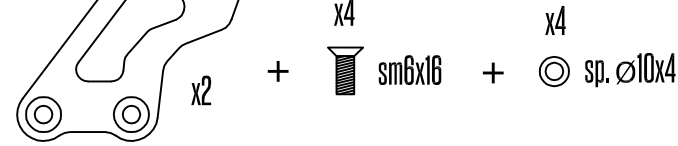

x2 + x4
sm6x16 + x4
sp. \varnothing 10x4

Bustina 4 - Bag 4
telaio - frame

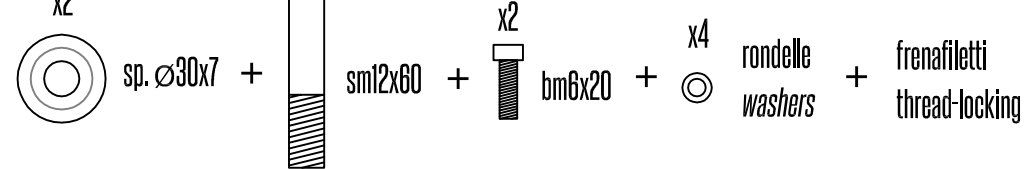

x2 + x2
sp. \varnothing 30x7 + sm12x60 + x2
bm6x20 + x4
rondelle washers + frenafillett thread-locking

Bustina 5 - Bag 5
telaio - frame

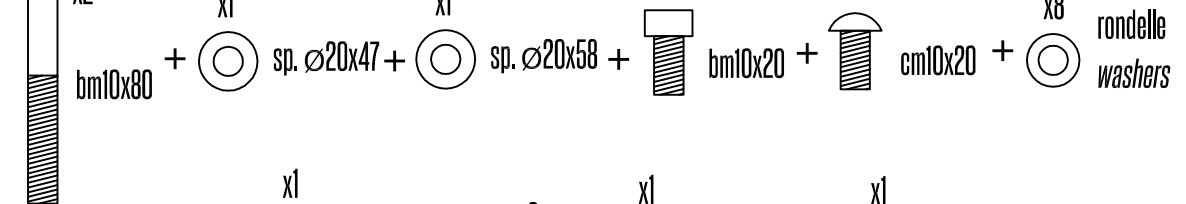

x2 + x1 + x1 + x1 + x1 + x8
bm10x80 + sp. \varnothing 20x47 + sp. \varnothing 20x58 + bm10x20 + cm10x20 + rondelle washers

Bustina 6 - Bag 6
cambio - gear

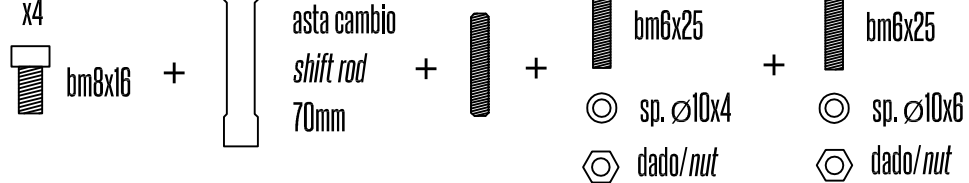

x4 + x1 + x2 + x1 + x1
bm8x16 + asta cambio shift rod 70mm + + bm6x25 + bm6x25
sp. \varnothing 10x4 + sp. \varnothing 10x6
dado/nut + dado/nut

Bustina 7 - Bag 7
solo con staffe passeggero - only with pillion pegs



x4 + x4
bm8x16 + rondelle washers

Bustina 8 - Bag 8
paratacchi per pedane passeggero - heel guards on pillion pegs



x2 + x4 + x4
sm6x16 + sp. \varnothing 10x4

Idrostop
se ordinato - if ordered



x2
rondelle washers

Ducati Hypermotard 620, 796, 1000, 1100 Evo, Multistrada

bm6x20

+ pompa freno/ *brake pump*

+ rondelle/ *washers*

+ A

sm12x60 + sp. $\varnothing 30 \times 7$ + A

sul telaio/ *on the frame*

cm10x20

Lato freno - *Brake side*

step 1

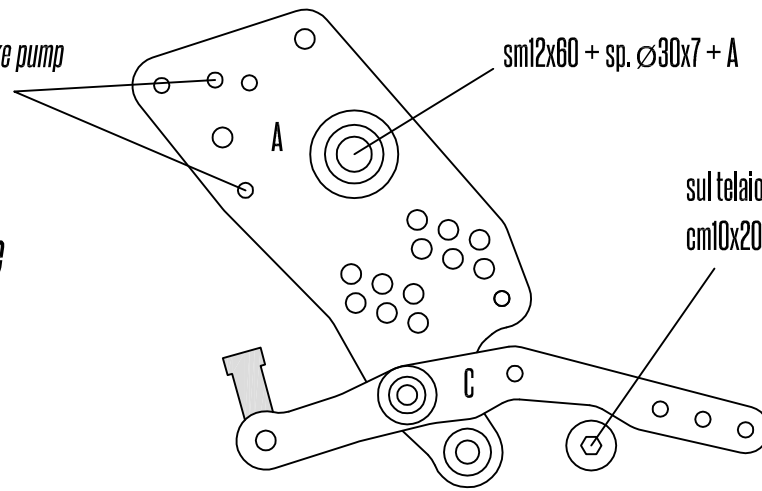

Lato freno - *Brake side*

step 2

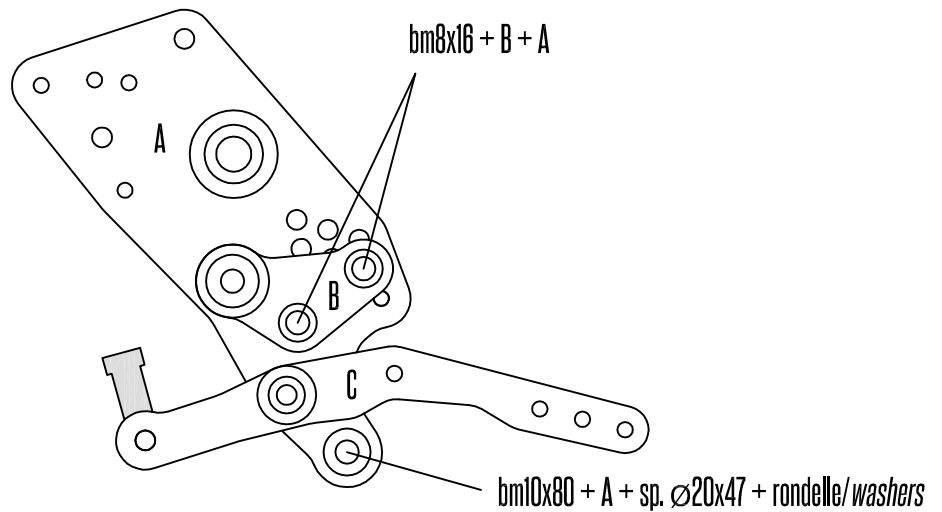

Lato freno - *Brake side*

step 3

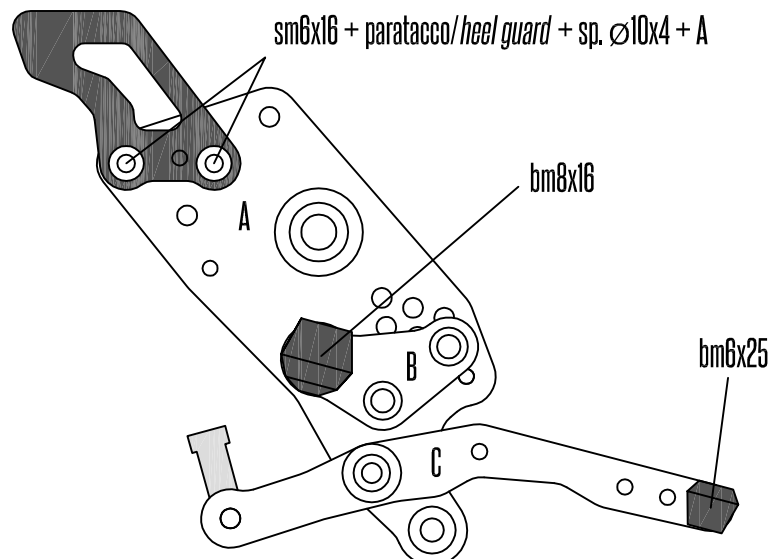

GeckoRacing

Ducati Hypermotard 620, 796, 1000, 1100 Evo, Multistrada

Lato cambio - *Gear side*

step 1

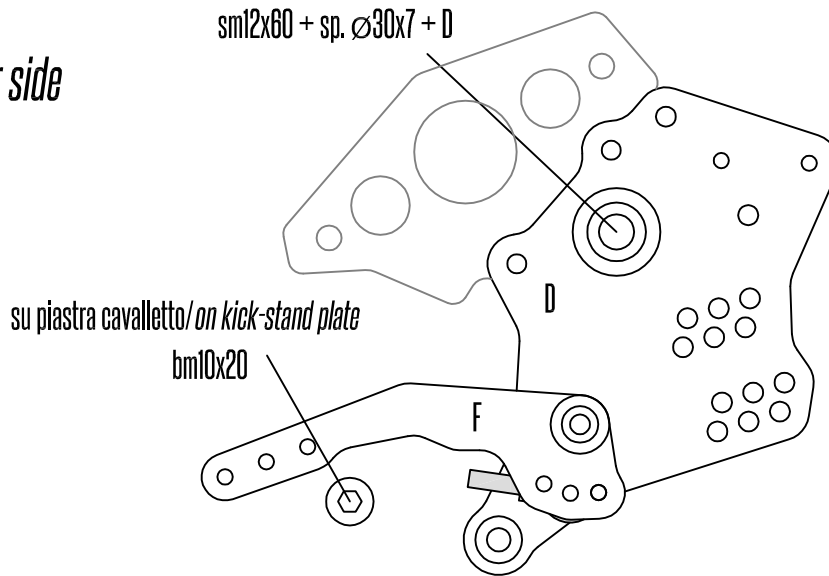

Lato cambio - *Gear side*

step 2

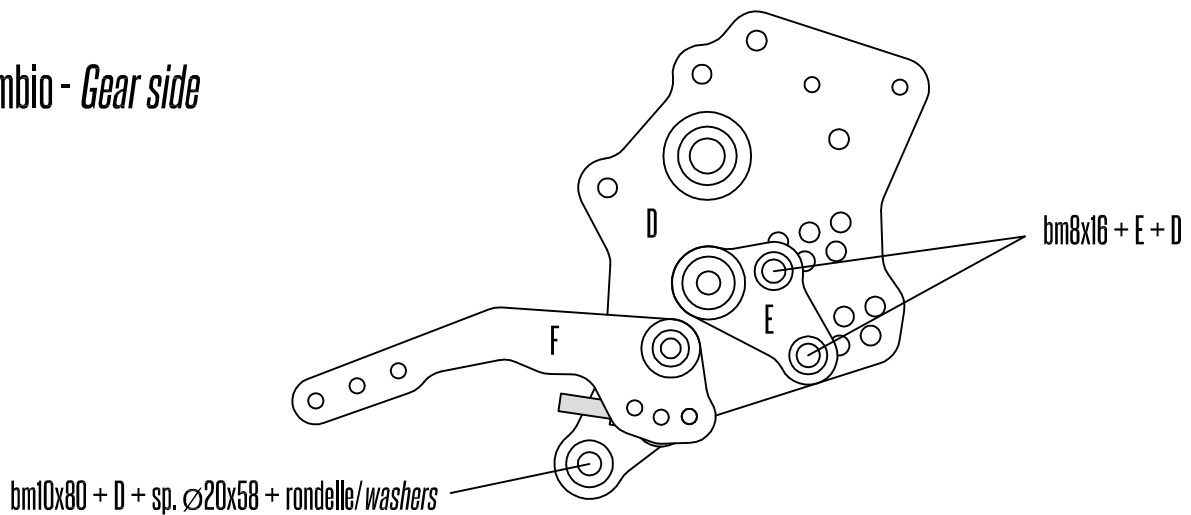

Lato cambio - *Gear side*

step 3

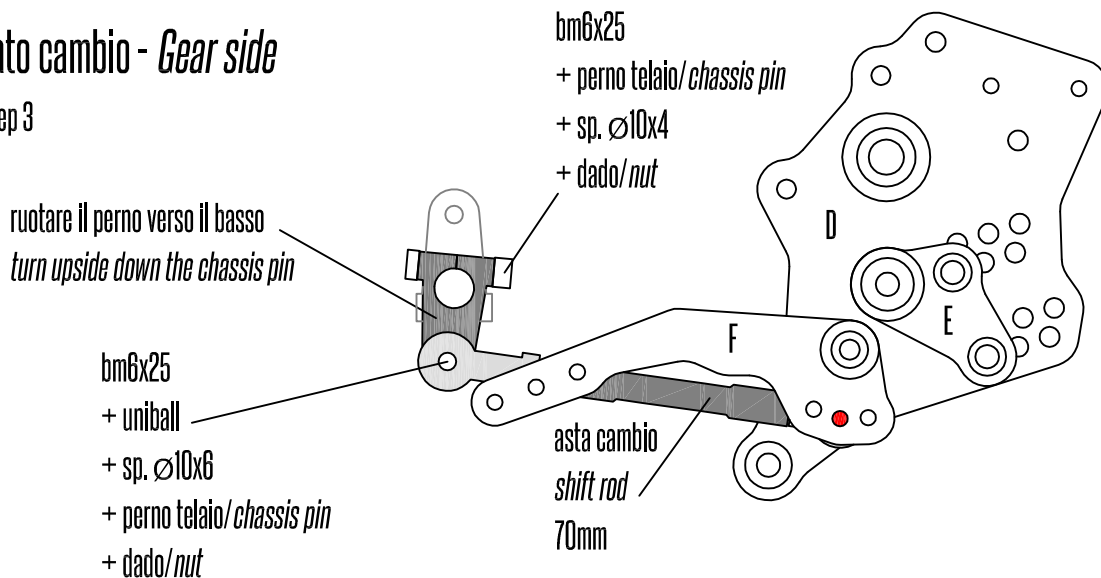

Ducati Hypermotard 620, 796, 1000, 1100 Evo, Multistrada

Lato cambio - *Gear side*

step 4

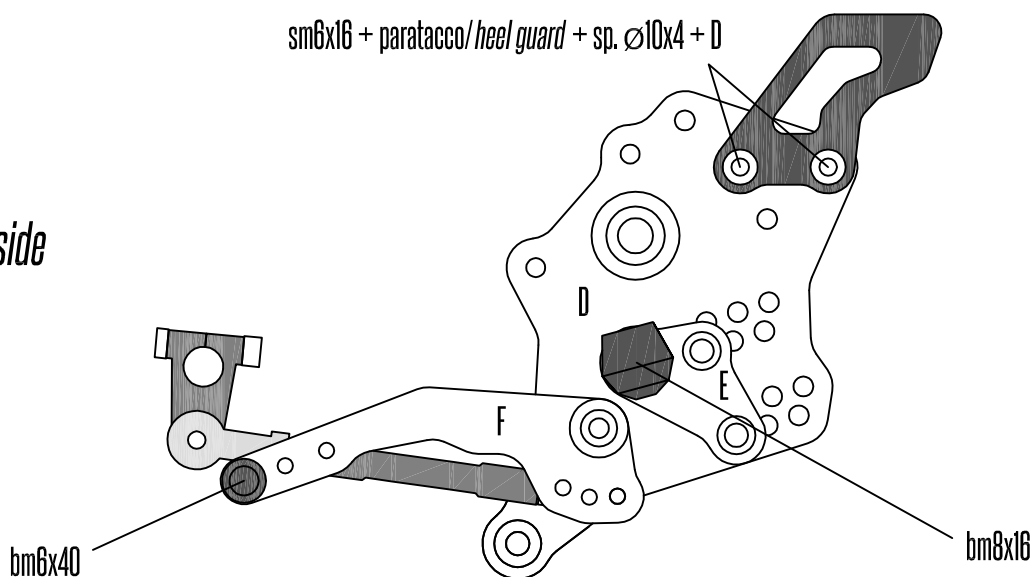

Cambio rovesciato - *Reverse gear*

ruotare leggermente il perno in senso orario
turn slightly clockwise the chassis pin

- bm6x25
- + uniball
- + sp. $\varnothing 10 \times 6$
- + perno telaio/*chassis pin*
- + dado/*nut*

asta cambio
shift rod
70mm

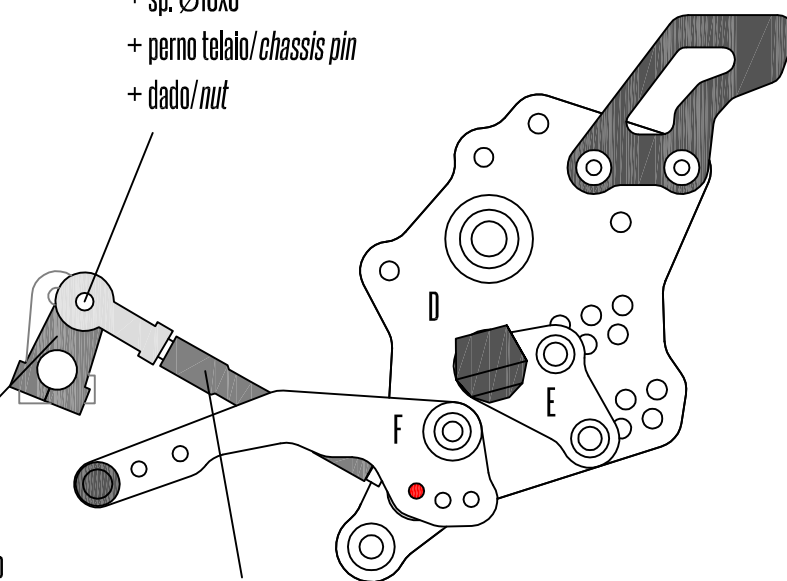

Ducati Hypermotard 620, 796, 1000, 1100 Evo, Multistrada

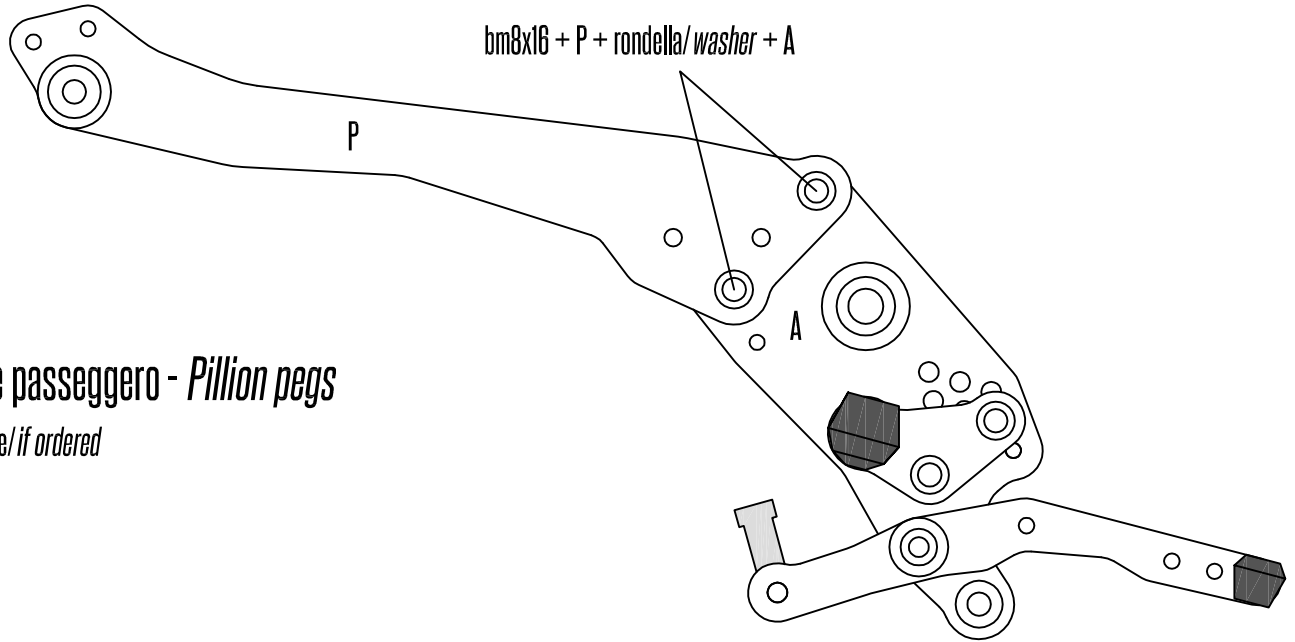

Pedane passeggero - Pillion pegs

se ordinate/ if ordered

step 1

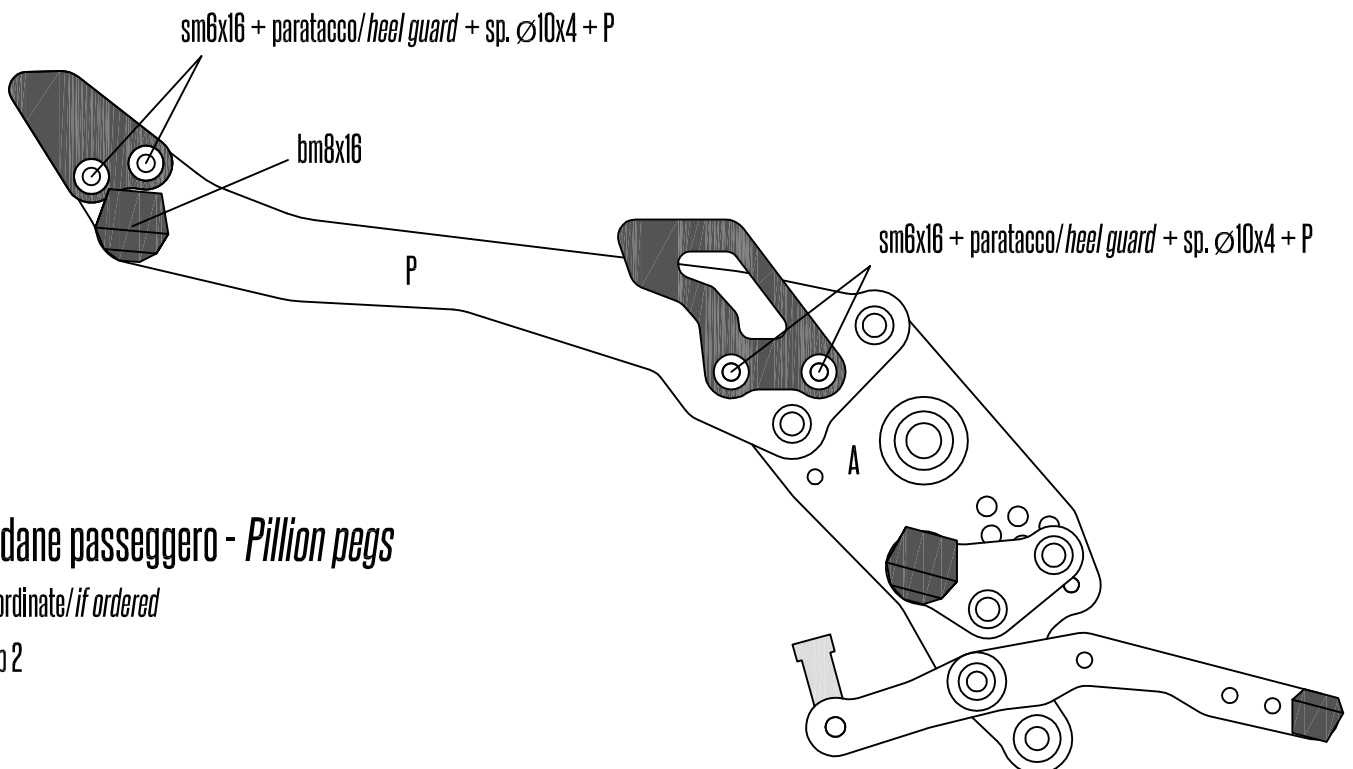

Pedane passeggero - Pillion pegs

se ordinate/ if ordered

step 2

Ducati Hypermotard 620, 796, 1000, 1100 Evo, Multistrada

Idrostop

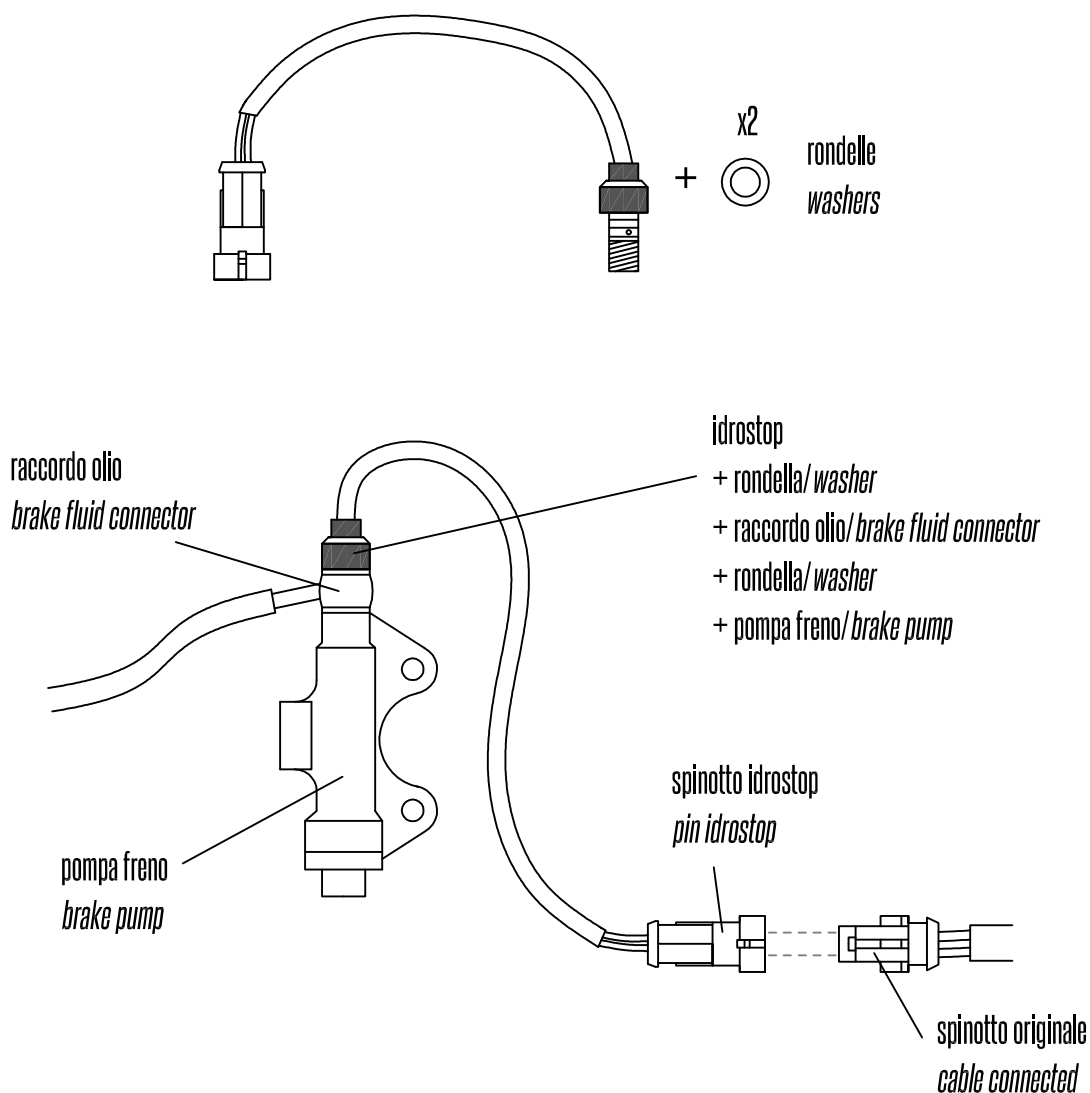

Su alcuni modelli di moto (es: MT-07 e Hornet >2007) lo spinotto originale è diverso da quello descritto nell'immagine.

Su altri modelli invece il cavo può risultare corto e non permette il collegamento con lo spinotto.

In questi due casi è necessario cablare i fili con l'idrostop per poterlo collegare, oppure usare altri fili come prolungha.

È consigliabile effettuare lo spurgo al termine del montaggio dell'idrostop, ma non è necessario se l'operazione viene effettuata correttamente.

For some models (ex: MT-07, Hornet >2007) the cable connected is different. In these case you need to cable the original one to connect on idrostop.

It's recommended to flush the brake fluid at the end of the idrostop mounting, but it's not necessary if the operation is successful.