

# GeckoRacing

## Ducati Hypermotard 821, 939

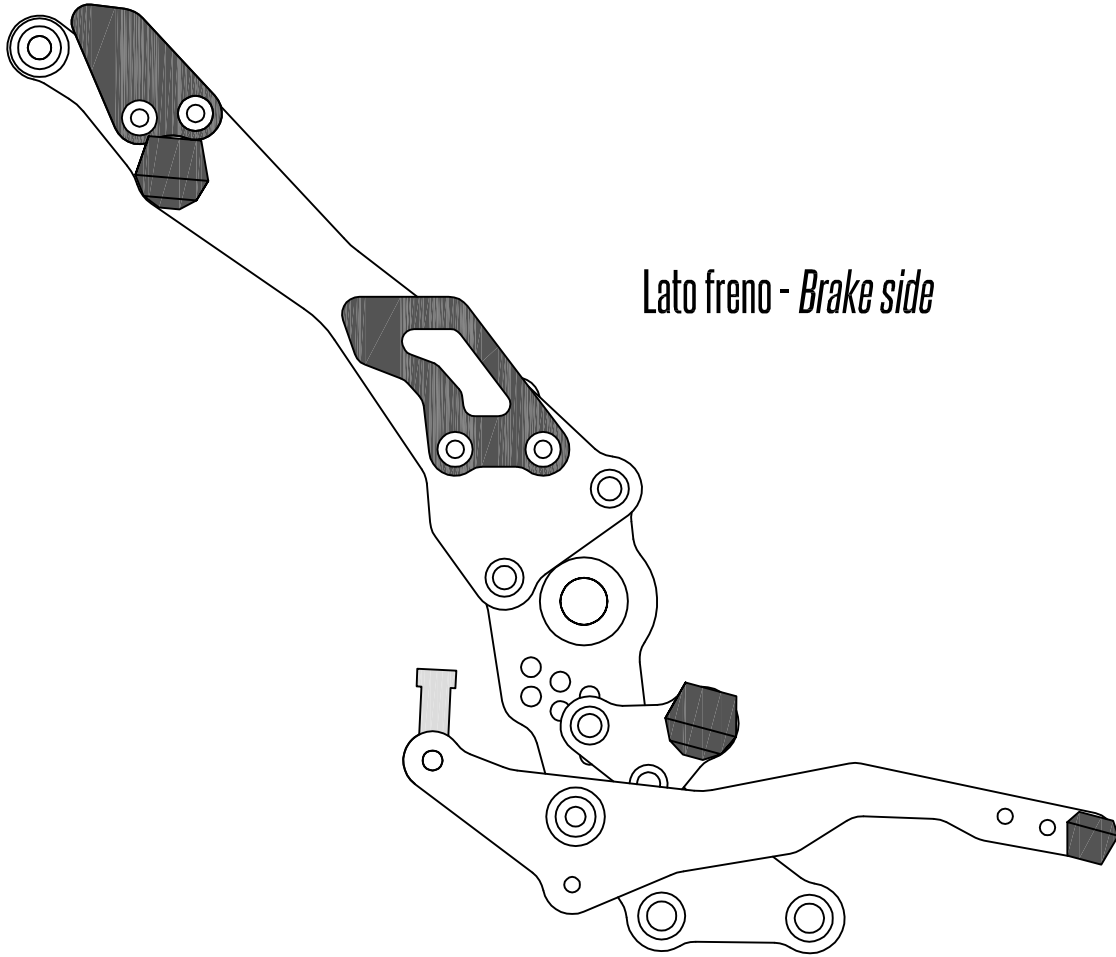

*Lato freno - Brake side*

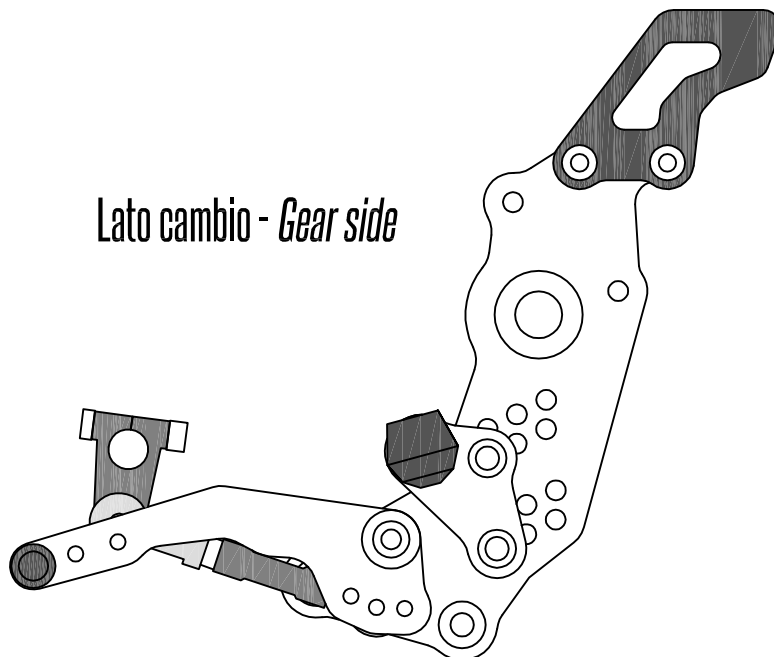

*Lato cambio - Gear side*

# GeckoRacing

## Ducati Hypermotard 821, 939

**Bustina 1 - Bag 1** - (x2 con pedane passeggero | x2 with pillion pegs)  
pedali poggiatesta - footrest pegs

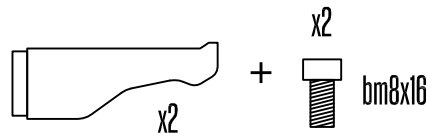

**Bustina 2 - Bag 2**  
pedalini leve - levers pedals

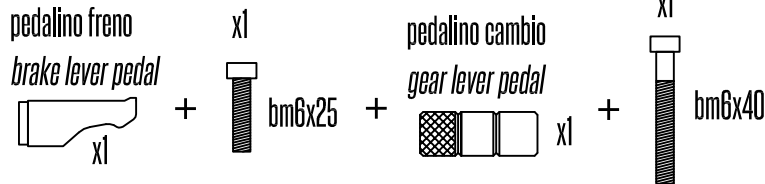

**Bustina 3 - Bag 3**  
paratacchi - heel guards

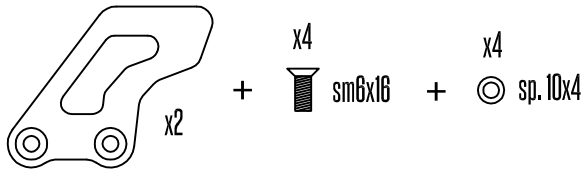

**Bustina 4 - Bag 4**  
telaio - frame



**Bustina 5 - Bag 5**  
telaio - frame

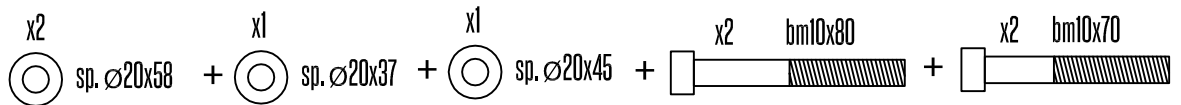

**Bustina 6 - Bag 6**  
pompa olio - oil pump

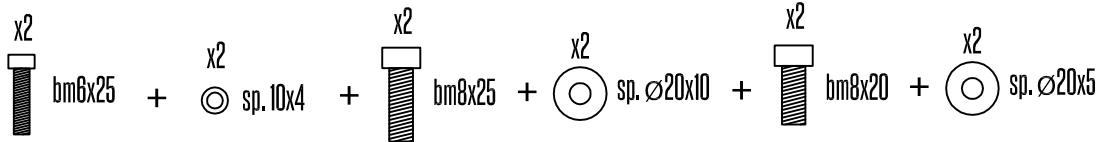

**Bustina 7 - Bag 7**  
cambio - gear

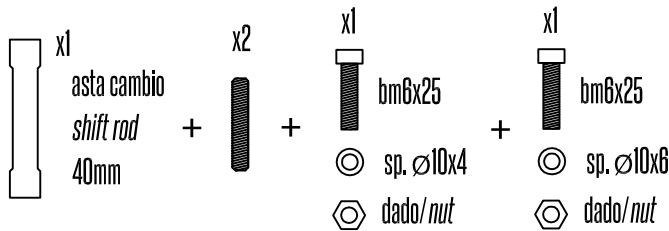

**Bustina 8 - Bag 8**

staffa scarico-pedane passeggero - bracket exhaust-pillion pegs

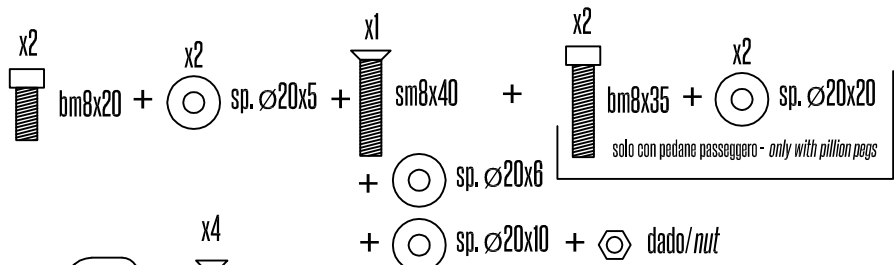

**Bustina 9 - Bag 9**

paratacchi per pedane passeggero - heel guards on pillion pegs

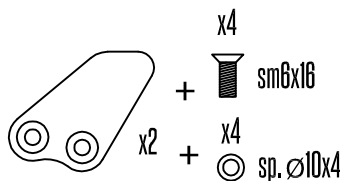

**Idrostop**

se ordinato - if ordered

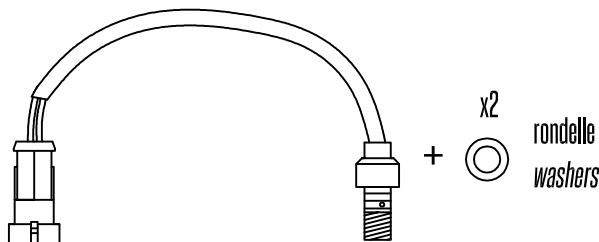

## Ducati Hypermotard 821, 939

Lato freno - *Brake side*  
step 1

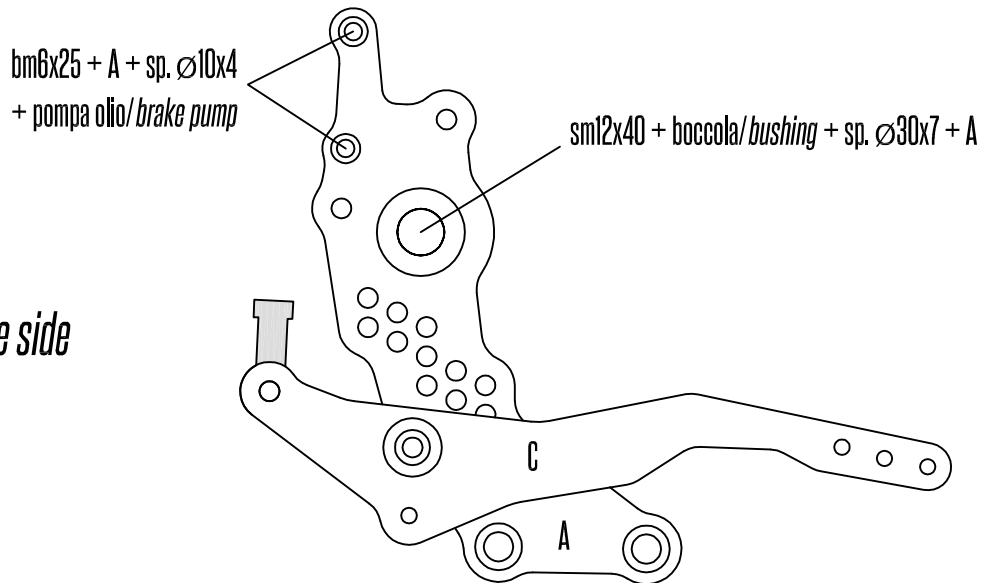

Lato freno - *Brake side*  
step 2

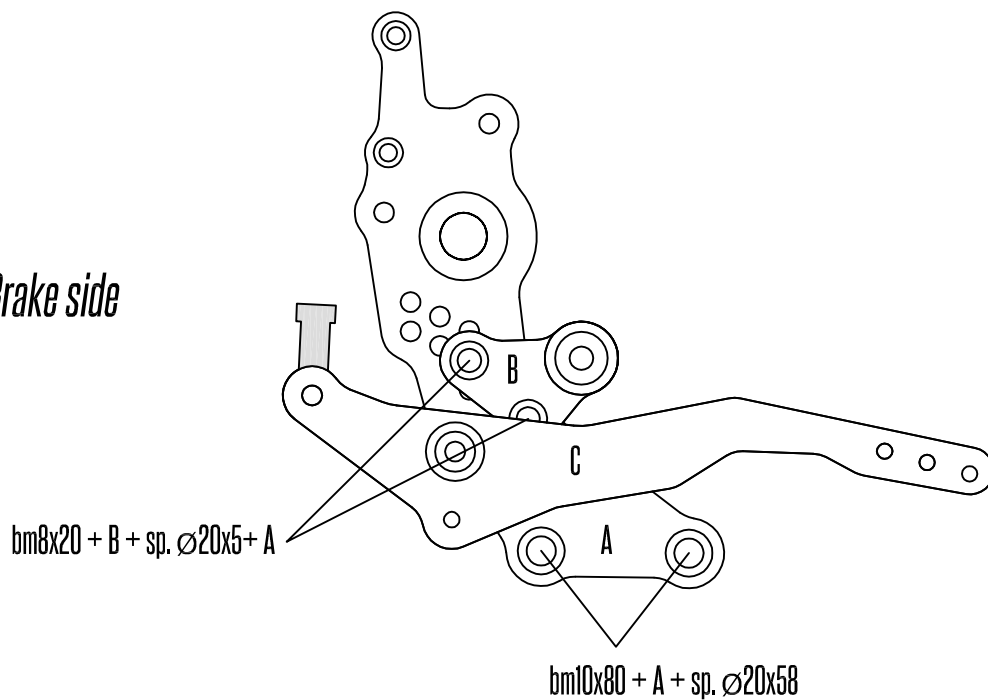

# GeckoRacing

## Ducati Hypermotard 821, 939

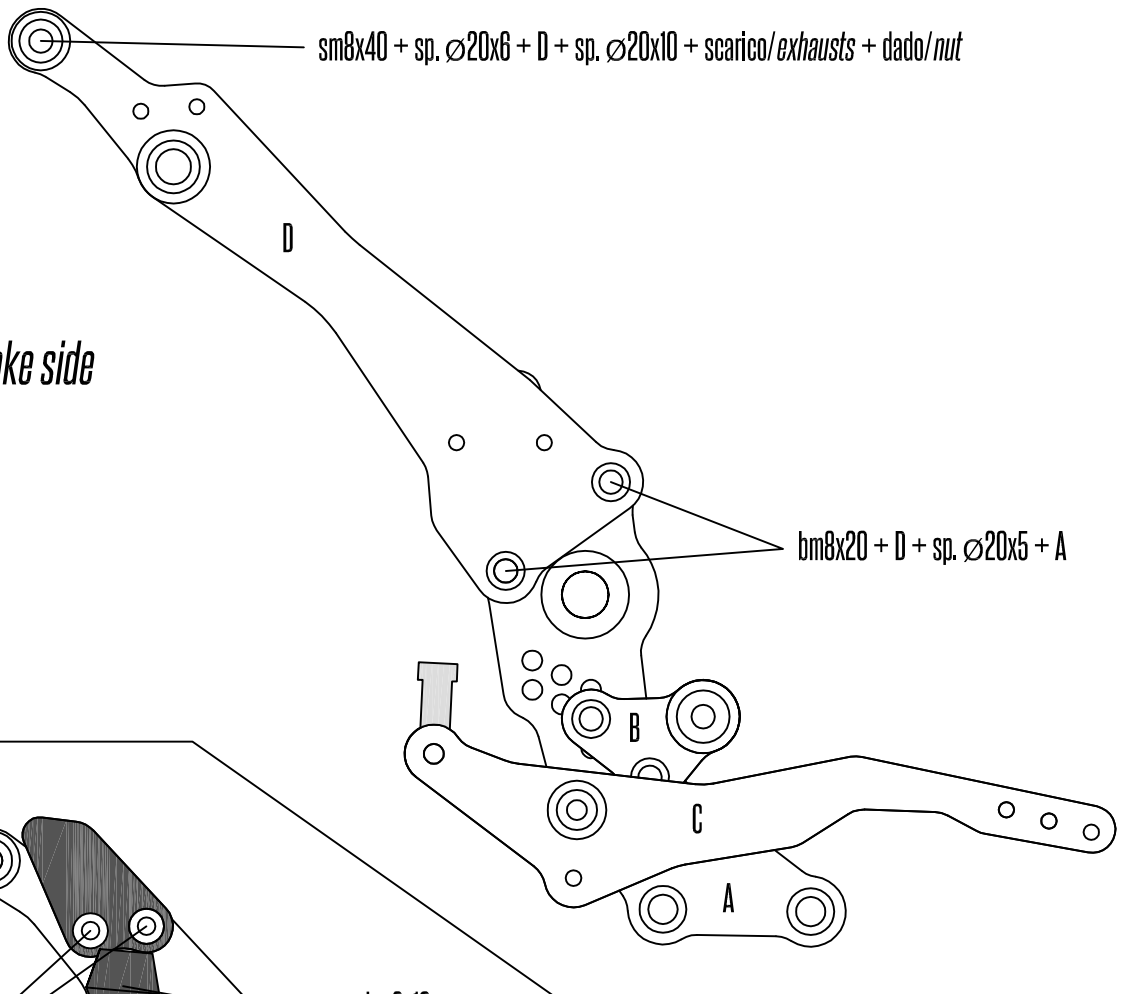

Lato freno - *Brake side*  
step 3

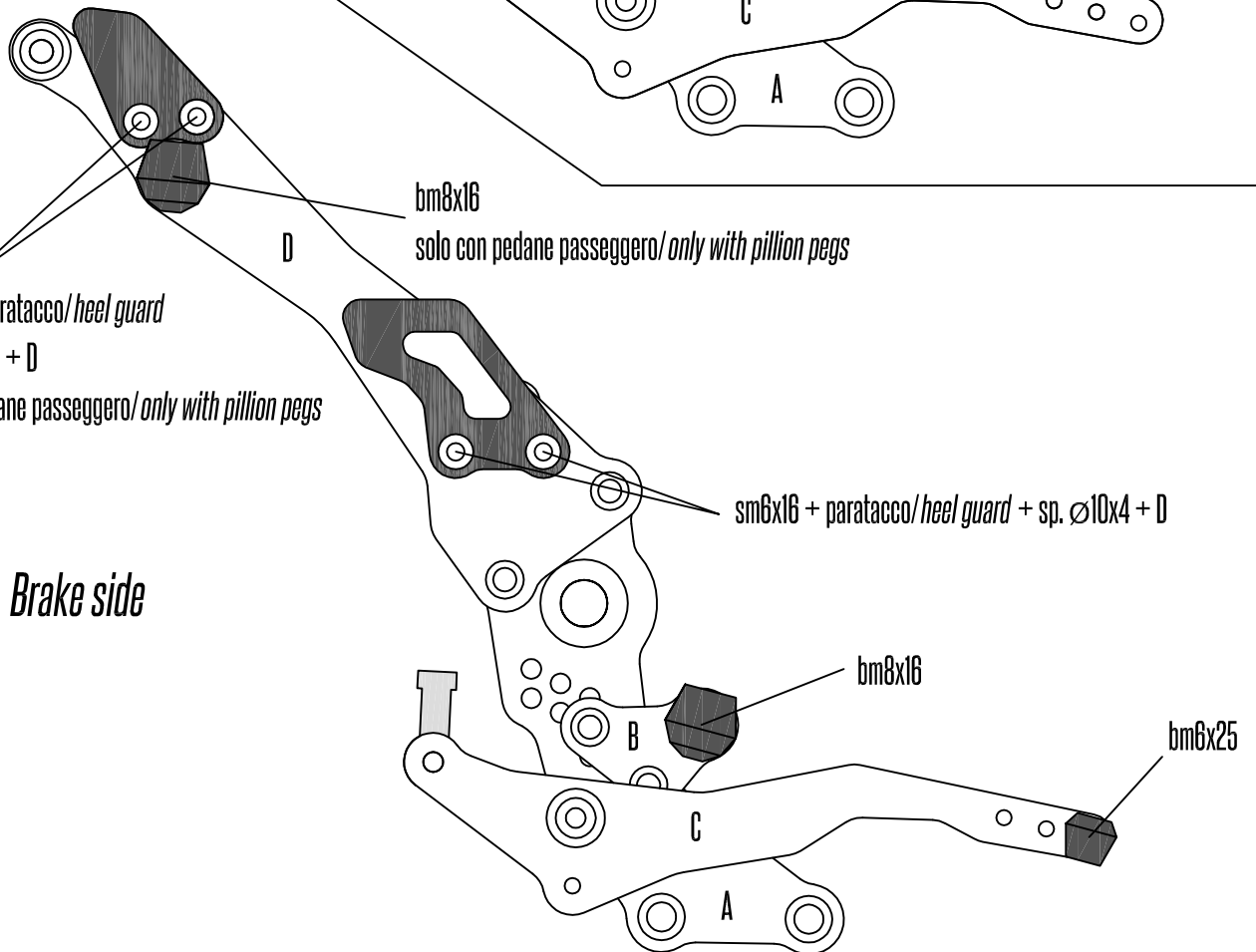

Lato freno - *Brake side*  
step 4

# GeckoRacing

## Ducati Hypermotard 821, 939

### Lato cambio - Gear side

step 1

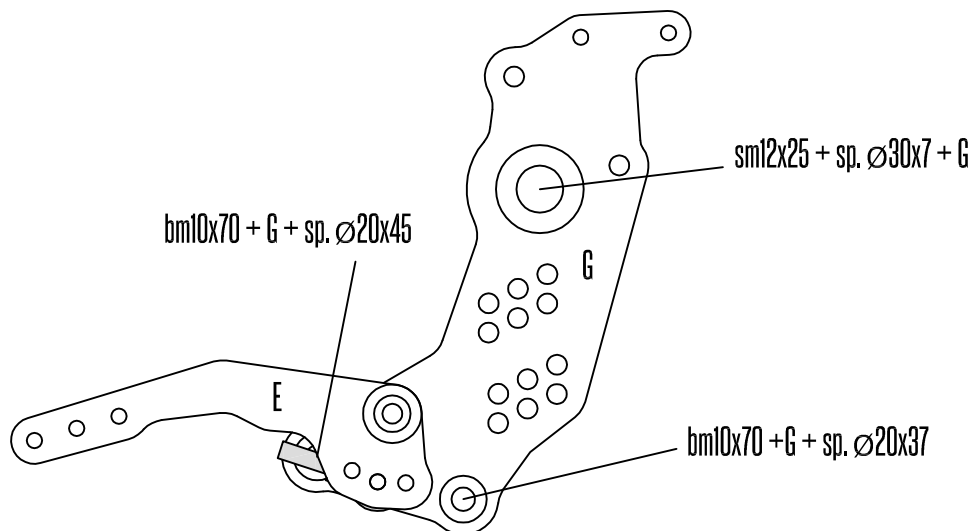

### Lato cambio - Gear side

step 2

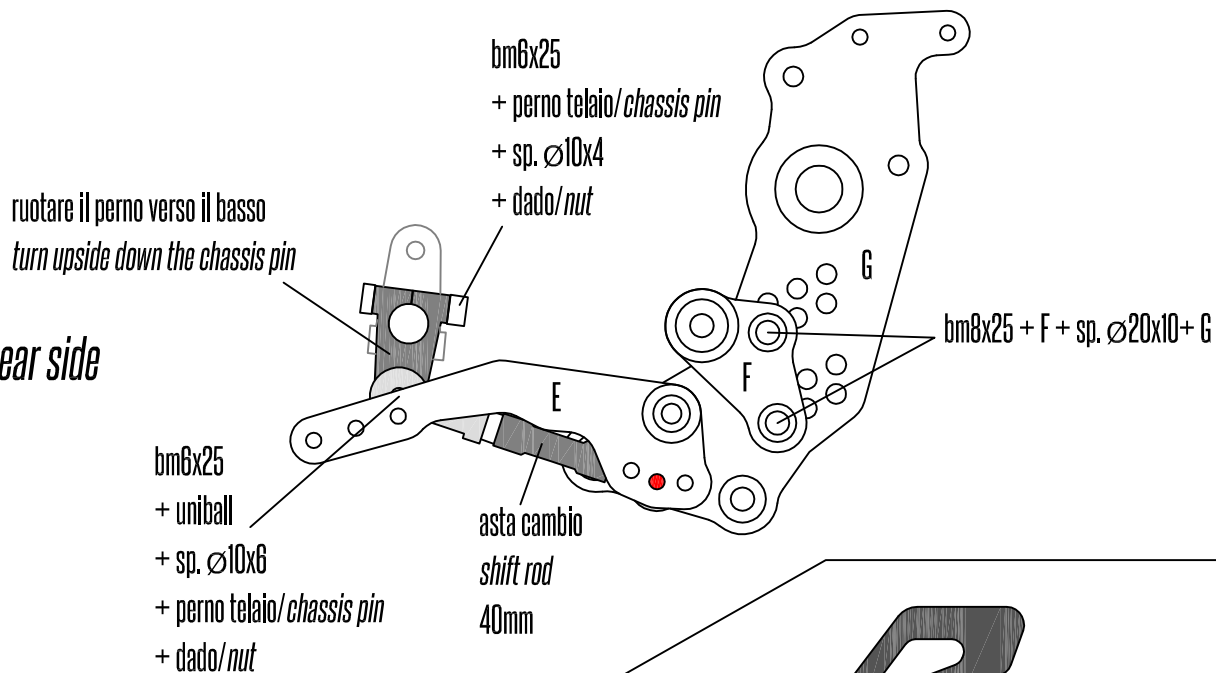

### Lato cambio - Gear side

step 3

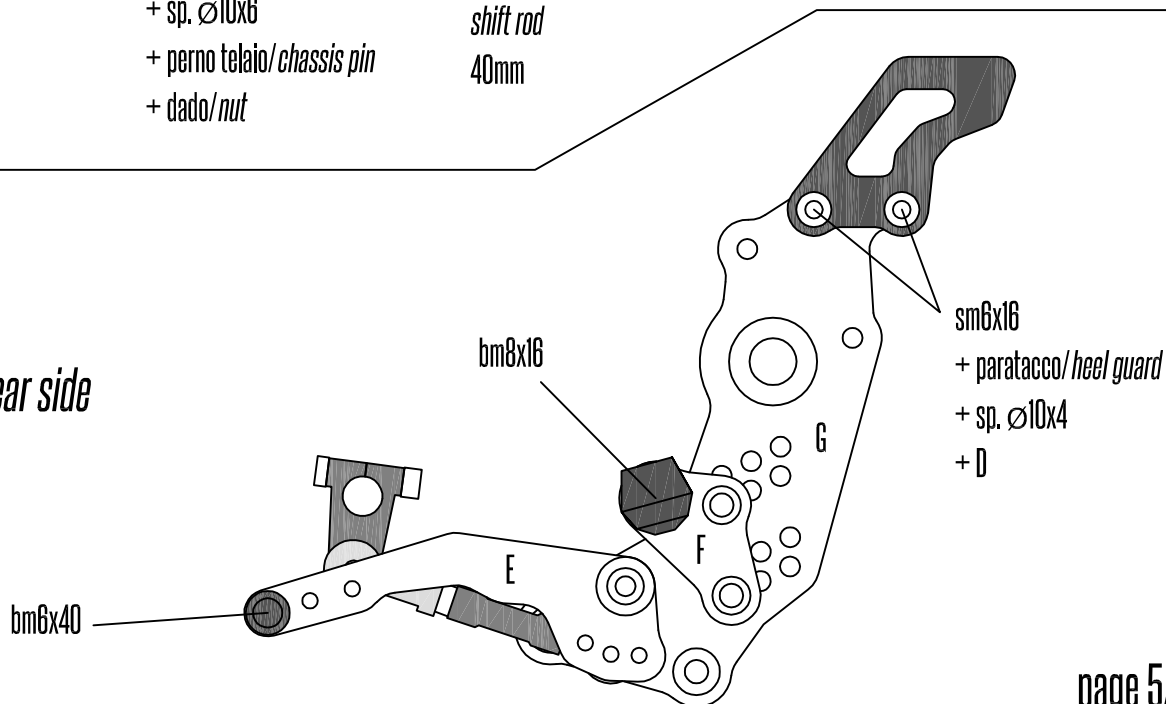

## Ducati Hypermotard 821, 939

### Cambio rovesciato - *Reverse gear*

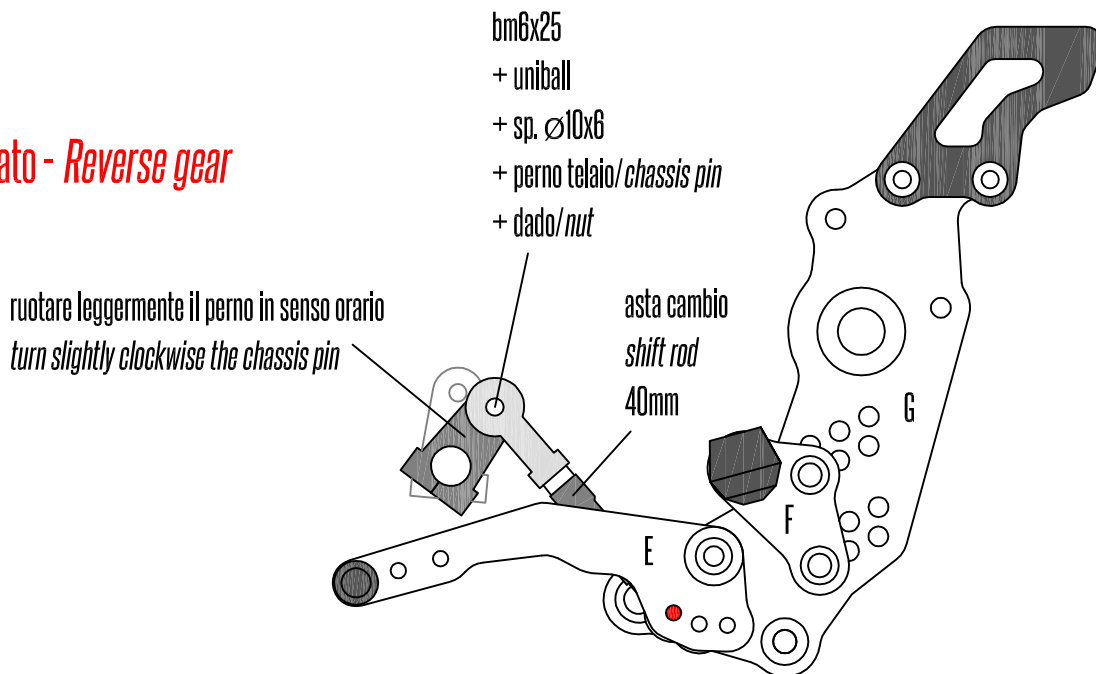

### Pedane passeggero - *Pillion pegs*

se ordinate / *if ordered*

step 1

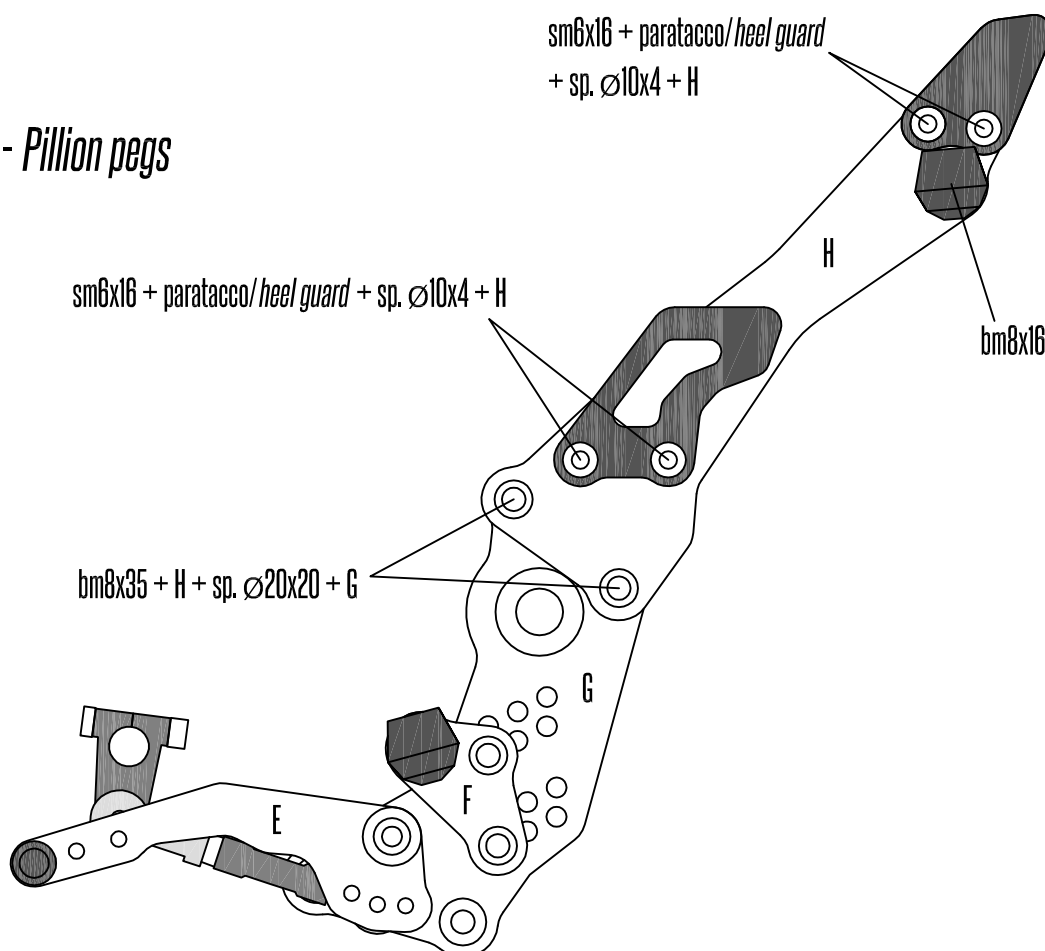

## Ducati Hypermotard 821, 939

### Idrostop

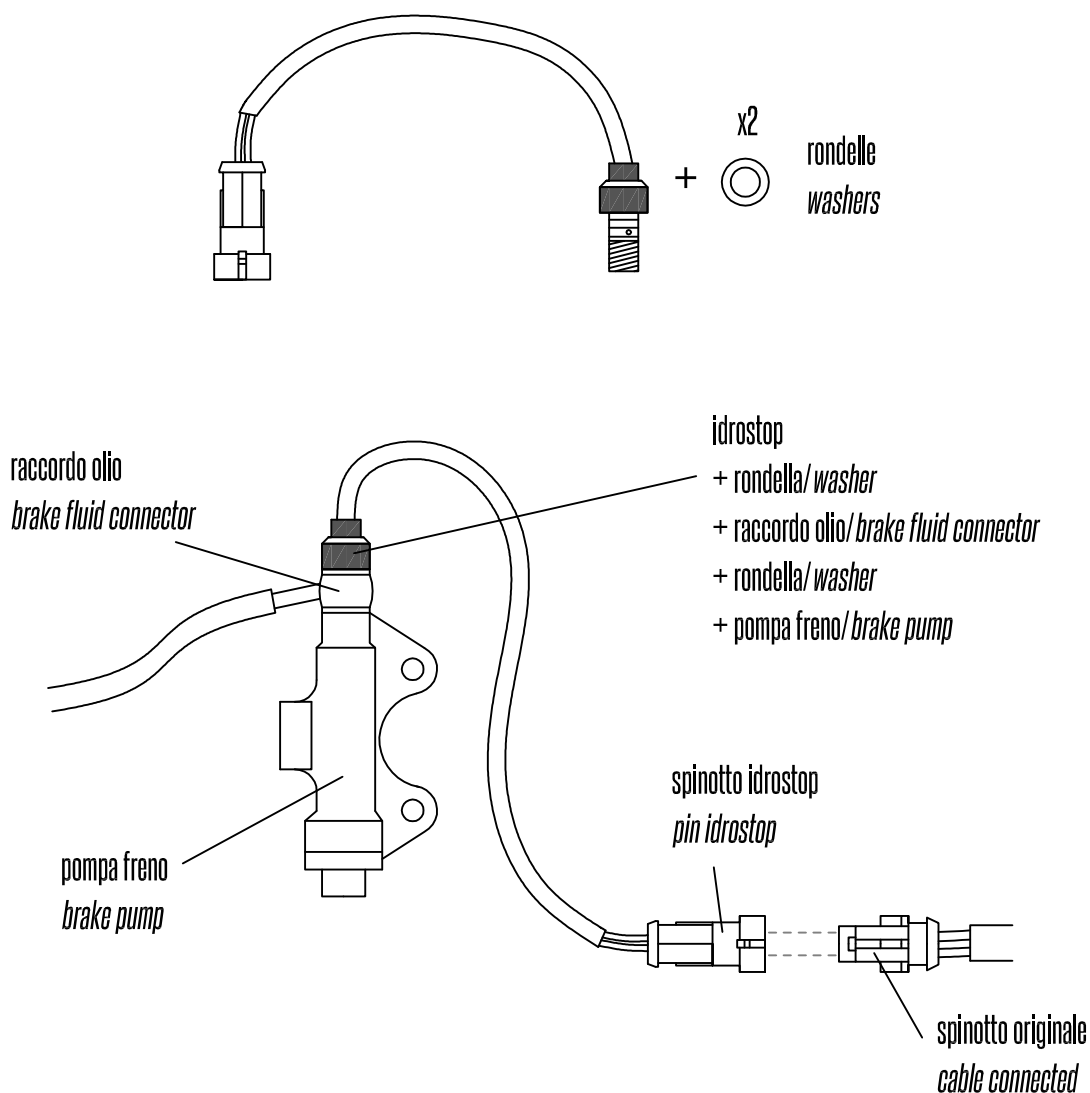

Su alcuni modelli di moto (es: MT-07 e Hornet >2007) lo spinotto originale è diverso da quello descritto nell'immagine.

Su altri modelli invece il cavo può risultare corto e non permette il collegamento con lo spinotto.

In questi due casi è necessario cablare i fili con l'idrostop per poterlo collegare, oppure usare altri fili come prolungha.

È consigliabile effettuare lo spurgo al termine del montaggio dell'idrostop, ma non è necessario se l'operazione viene effettuata correttamente.

*For some models (ex: MT-07, Hornet >2007) the cable connected is different. In these case you need to cable the original one to connect on idrostop.*

*It's recommended to flush the brake fluid at the end of the idrostop mounting, but it's not necessary if the operation is successful.*