

Ducati Monster 821, 1200 (2014-2016)

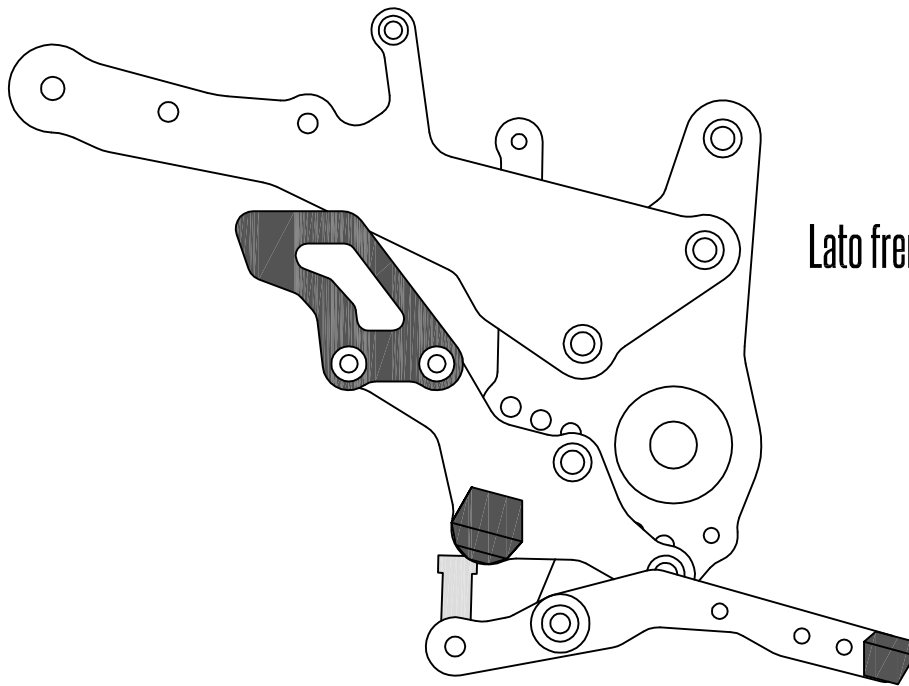

Lato freno - *Brake side*

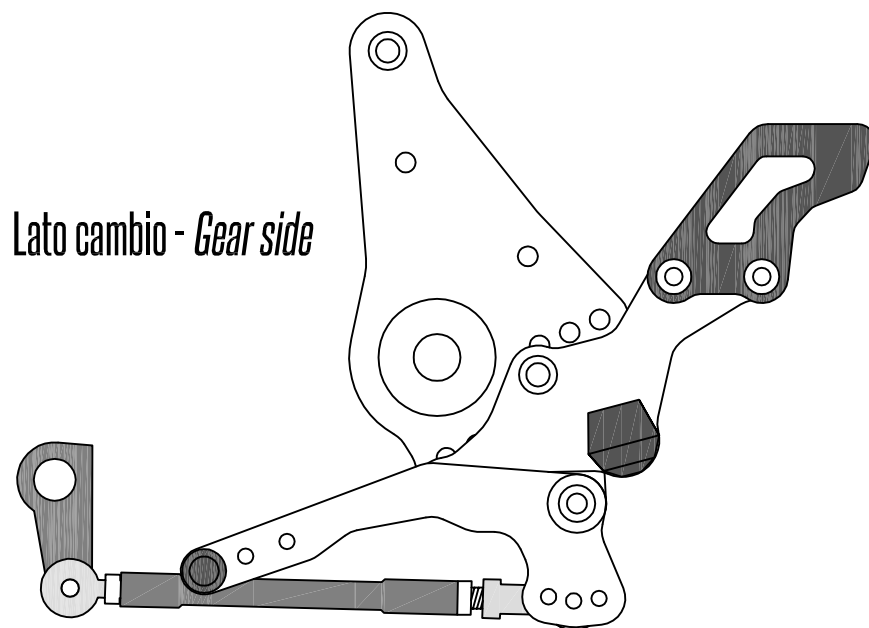

Lato cambio - *Gear side*

GeckoRacing

Ducati Monster 821, 1200 (2014-2016)

Bustina 1 - Bag 1 - (x2 con pedane passeggero | x2 with pillion pegs)
pedali poggiapiedi - footrest pegs

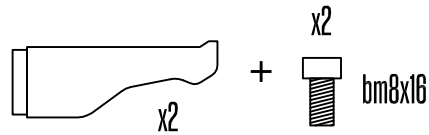

Bustina 2 - Bag 2
pedalini leve - levers pedals

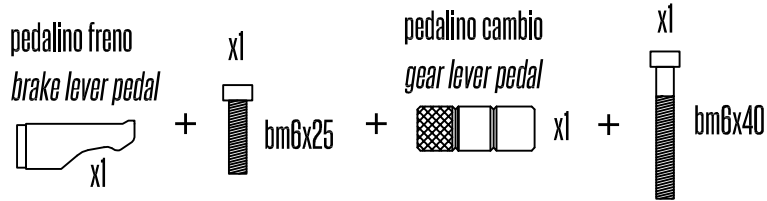

Bustina 3 - Bag 3
paratacchi - heel guards

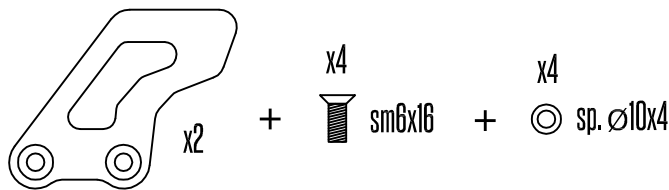

Bustina 4 - Bag 4
telaio - frame

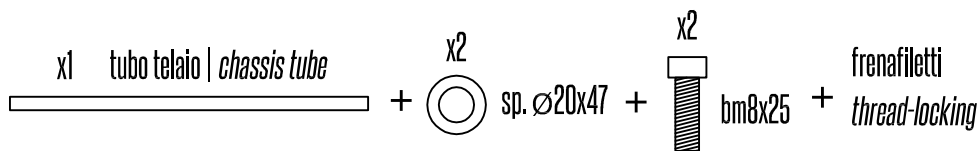

Bustina 5 - Bag 5
cambio e olio - gear and oil

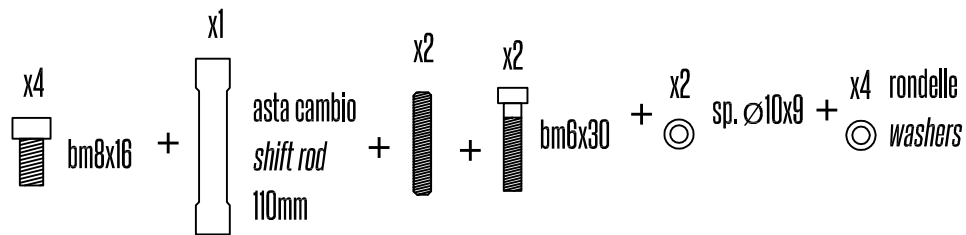

Bustina 6 - Bag 6
staffa scarico e pedane passeggero
exhaust bracket and pillion pegs

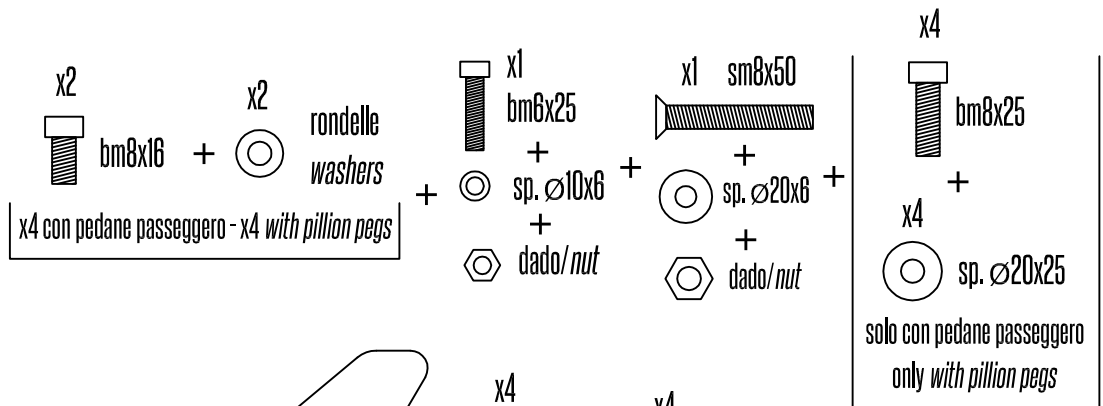

Bustina 7 - Bag 7
paratacchi per pedane passeggero - heel guards on pillion pegs

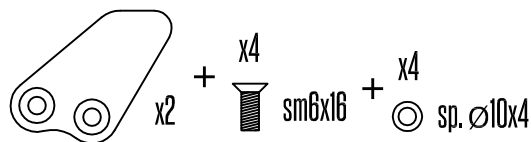

Idrostop
se ordinato - if ordered

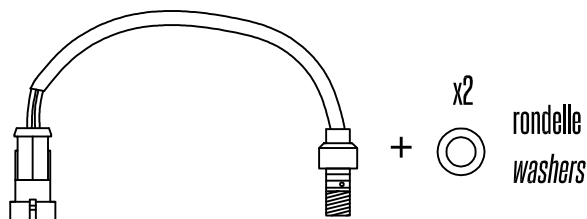

Ducati Monster 821, 1200 (2014-2016)

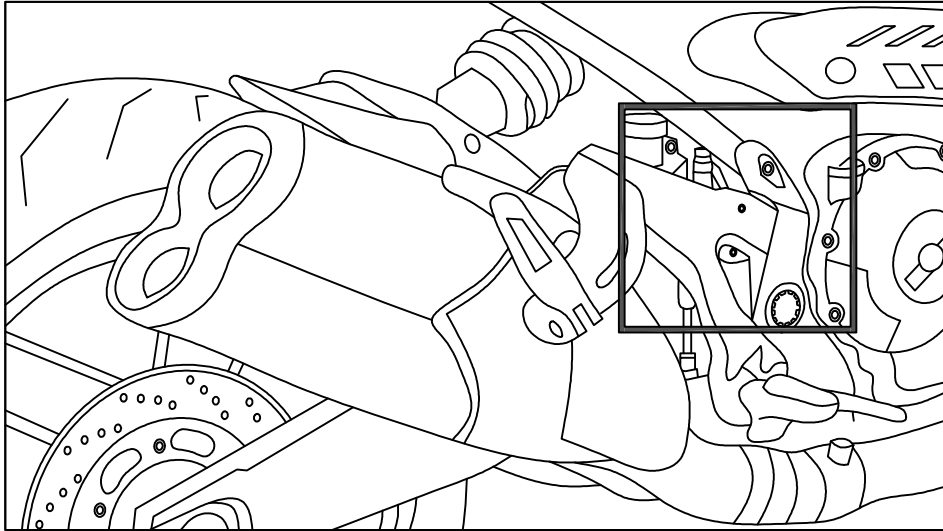

Smontare i perni esagonali ed estrarre il tubo del telaio fissato in alto sul blocco delle pedane originali.
Infilare nuovo tubo fornito nel kit facendo attenzione ad equilibrare la distanza di uscita nei due lati (circa 45mm).

*Dismount the original hexagonal bolts, and remove the chassis tube locked at the top on the block of the original rearsets.
Insert the new chassis tube taking care to balance the output distance on both sides (about 45 mm).*

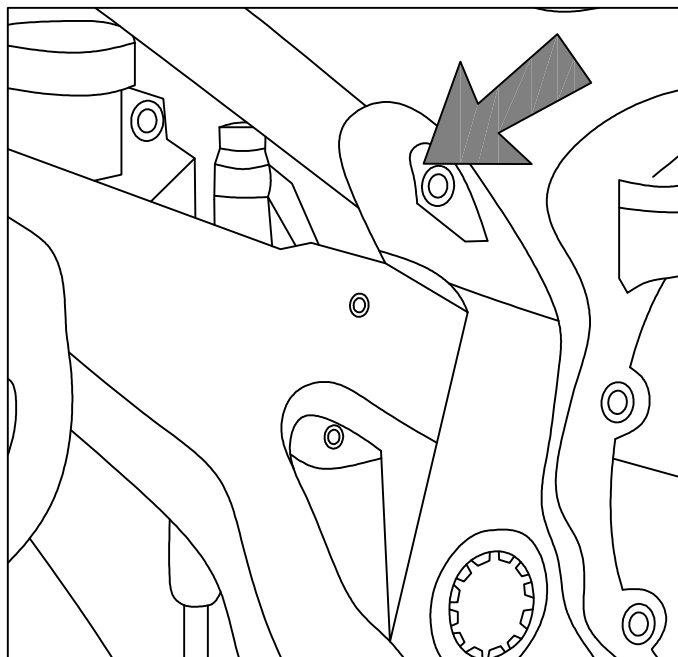

Ducati Monster 821, 1200 (2014-2016)

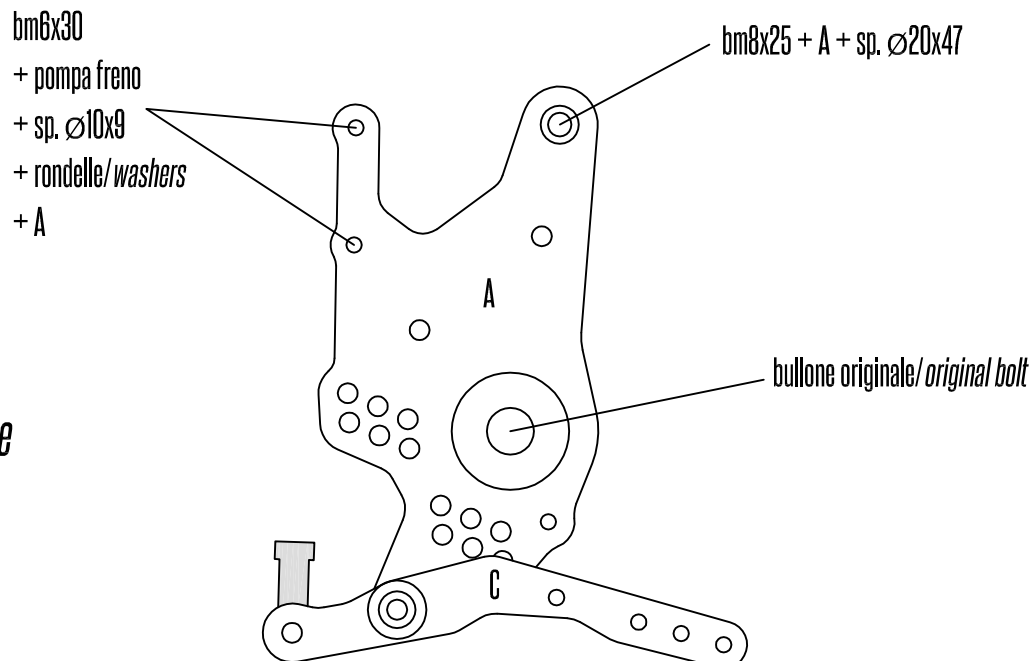

Lato freno - *Brake side*
step 1

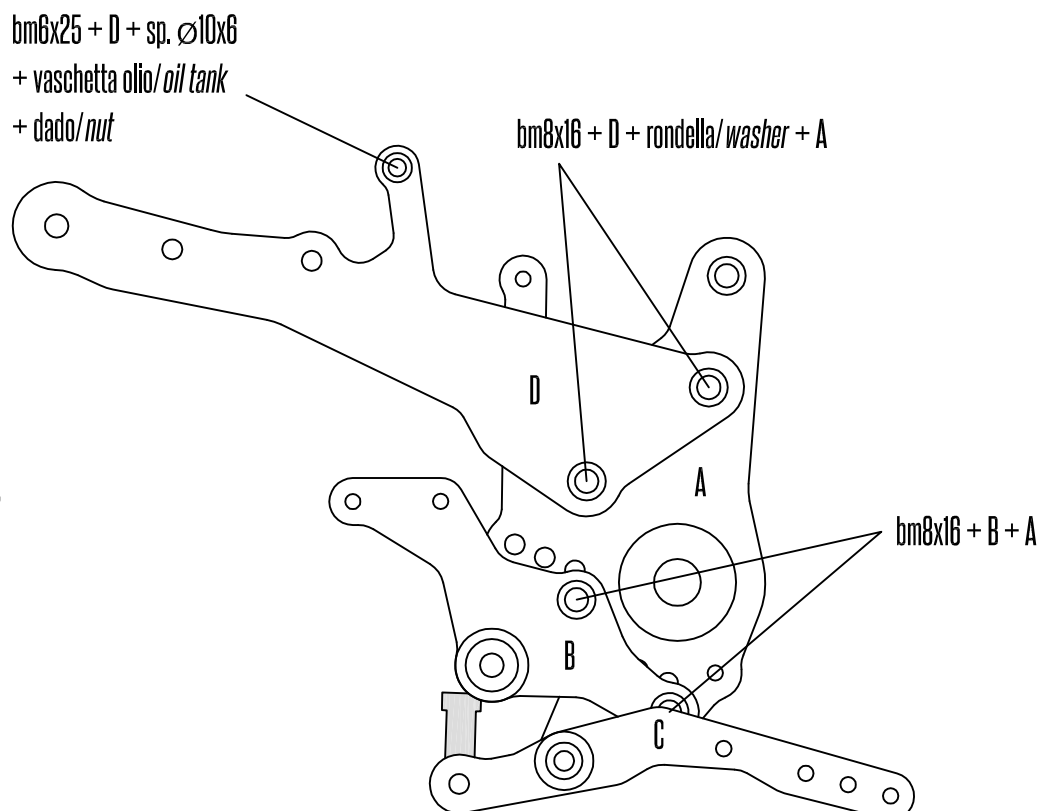

Lato freno - *Brake side*
step 2

Ducati Monster 821, 1200 (2014-2016)

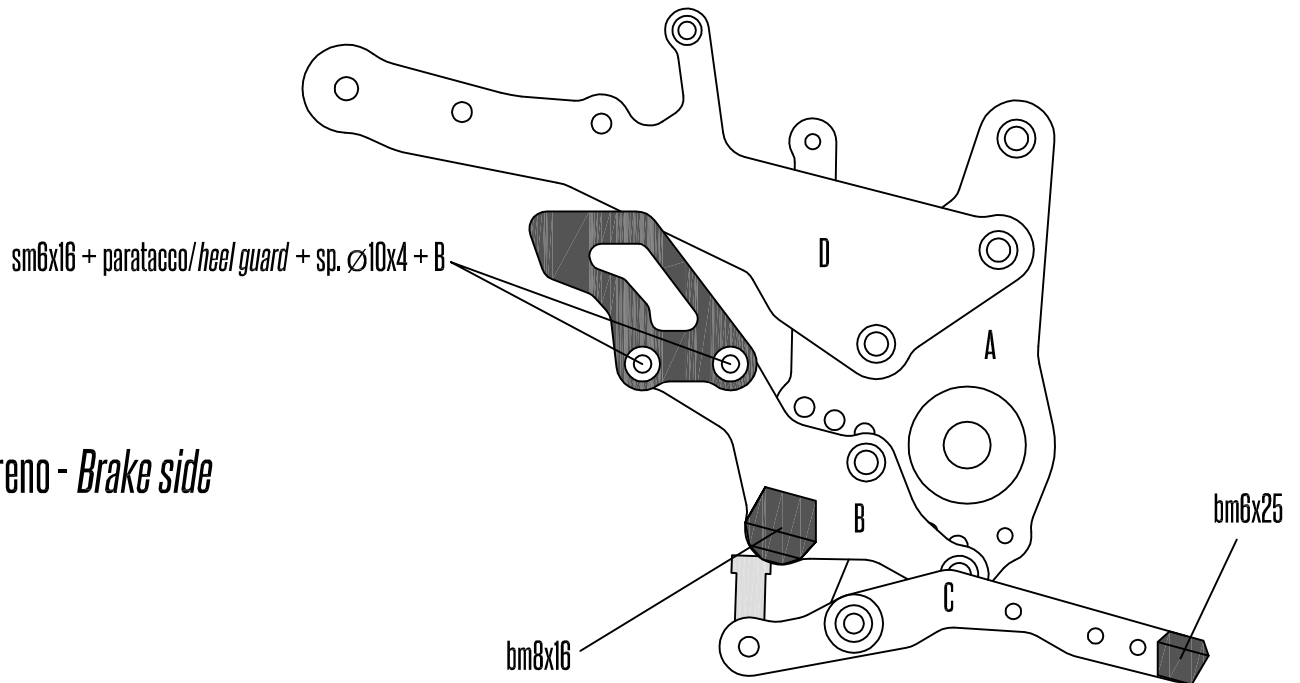

Lato cambio - Gear side

step 1

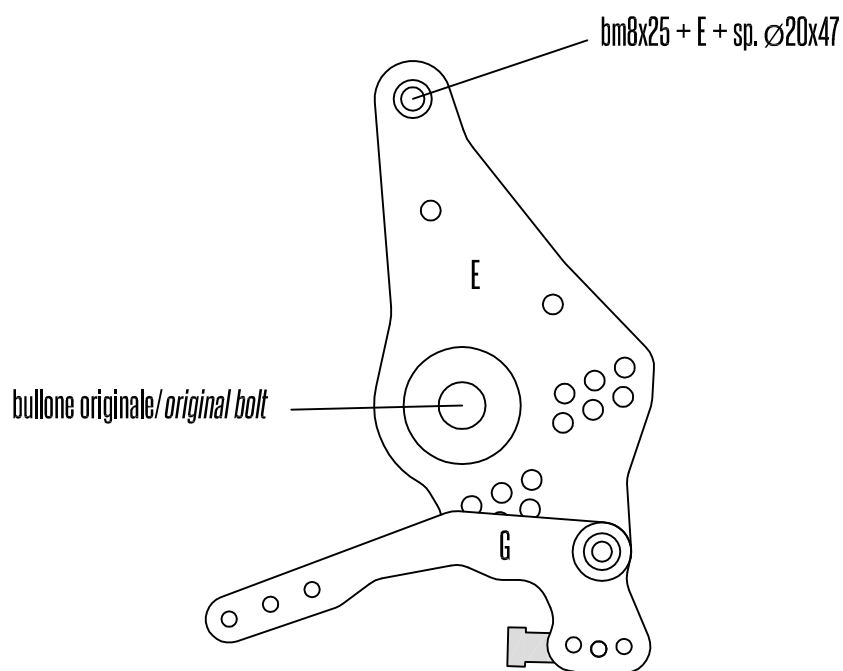

Ducati Monster 821, 1200 (2014-2016)

Lato cambio - *Gear side*
step 2

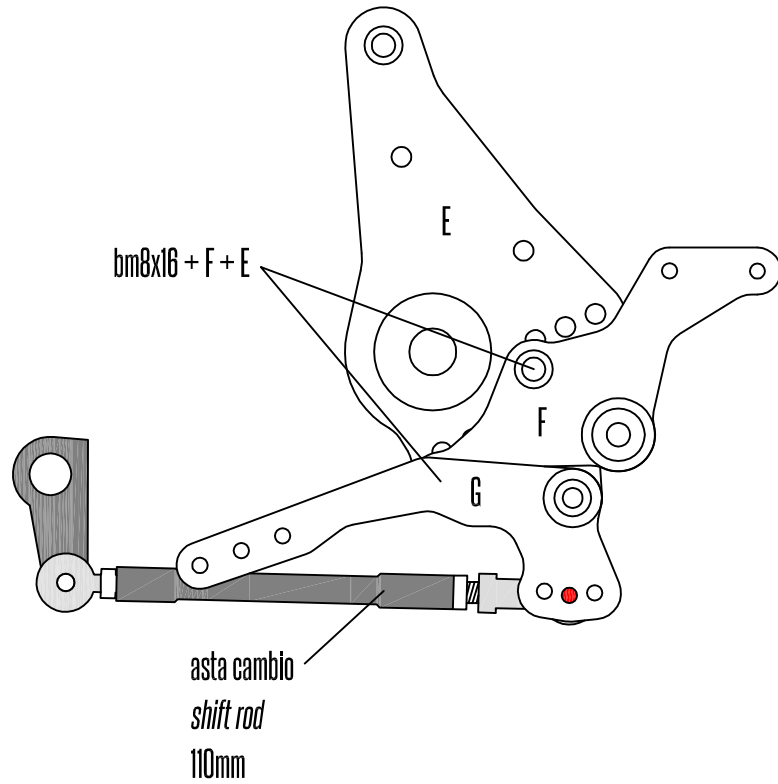

Lato cambio - *Gear side*
step 3

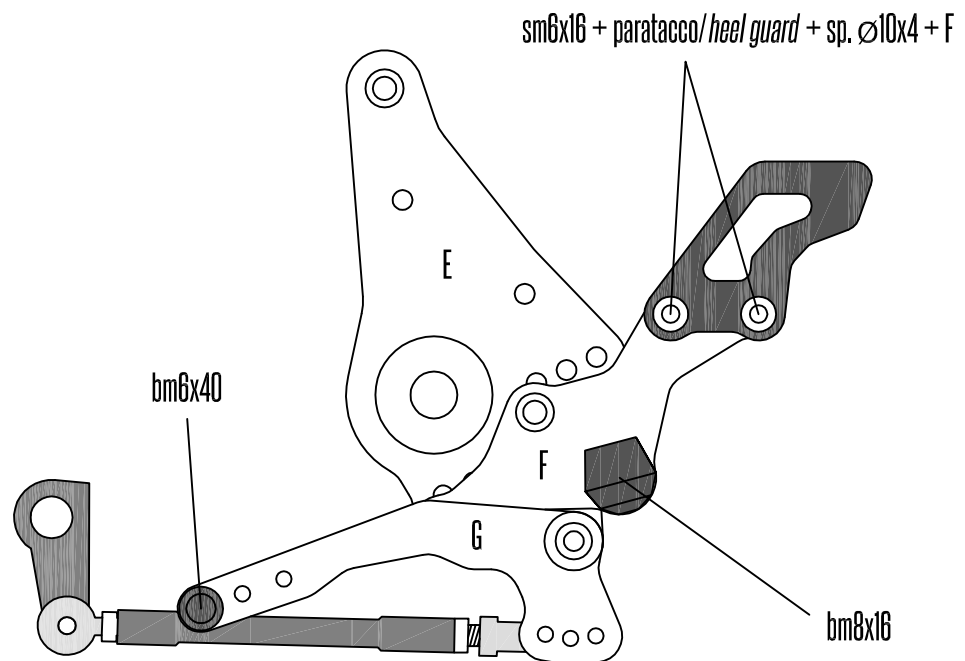

Ducati Monster 821, 1200 (2014-2016)

Pedane passeggero - Pillion pegs

se ordinate/if ordered

step 1

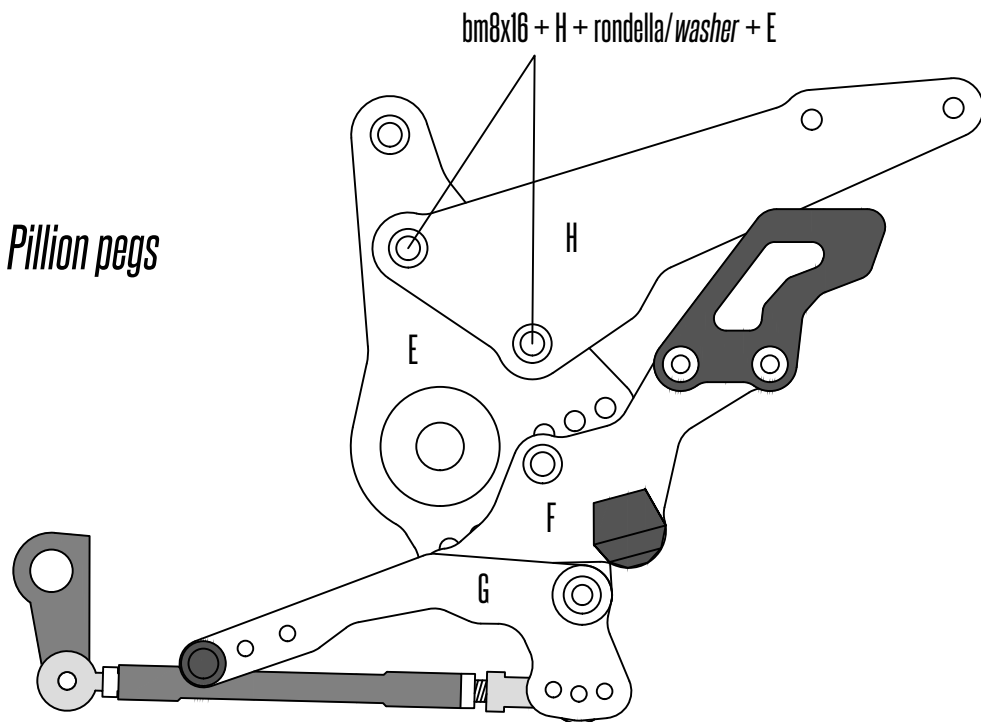

Ducati Monster 821, 1200 (2014-2016)

Pedane passeggero - Pillion pegs

se ordinate/ if ordered

step 2

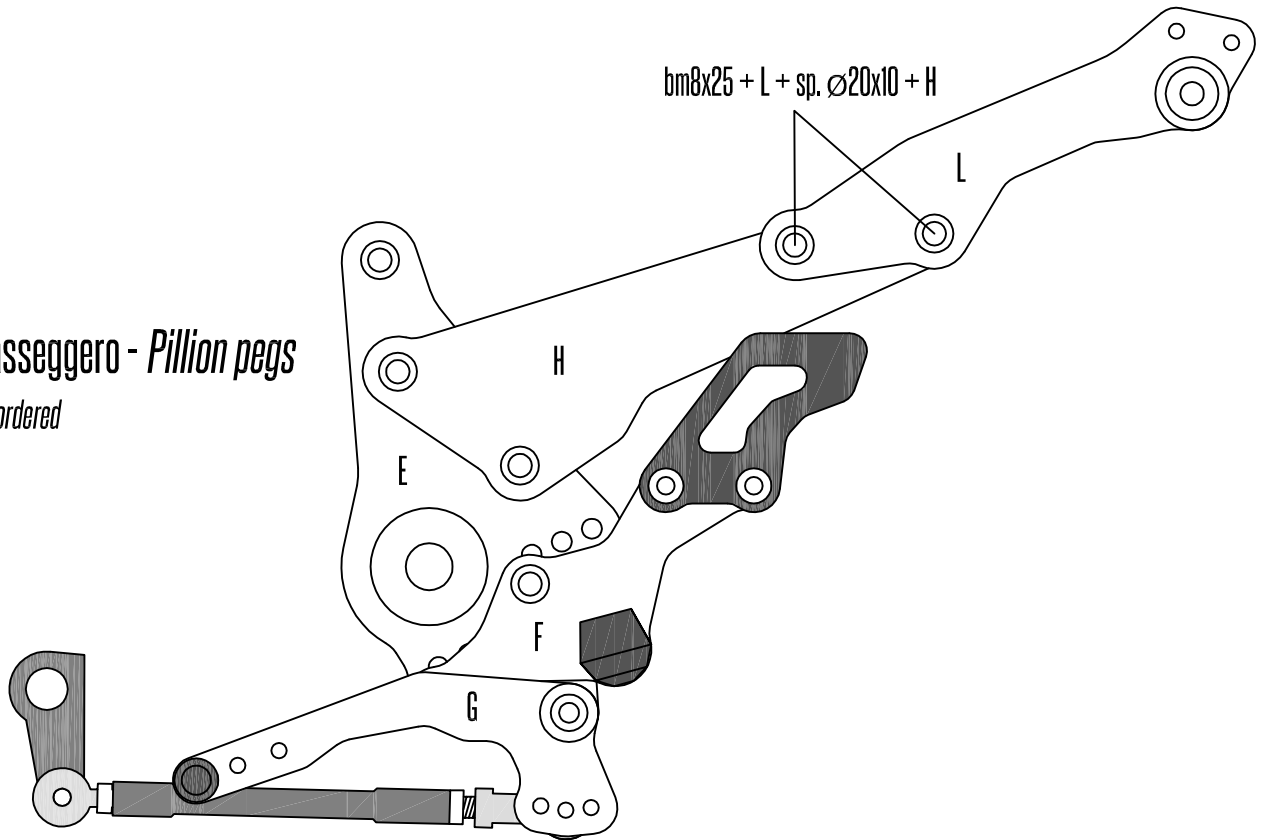

Pedane passeggero - Pillion pegs

se ordinate/ if ordered

step 3

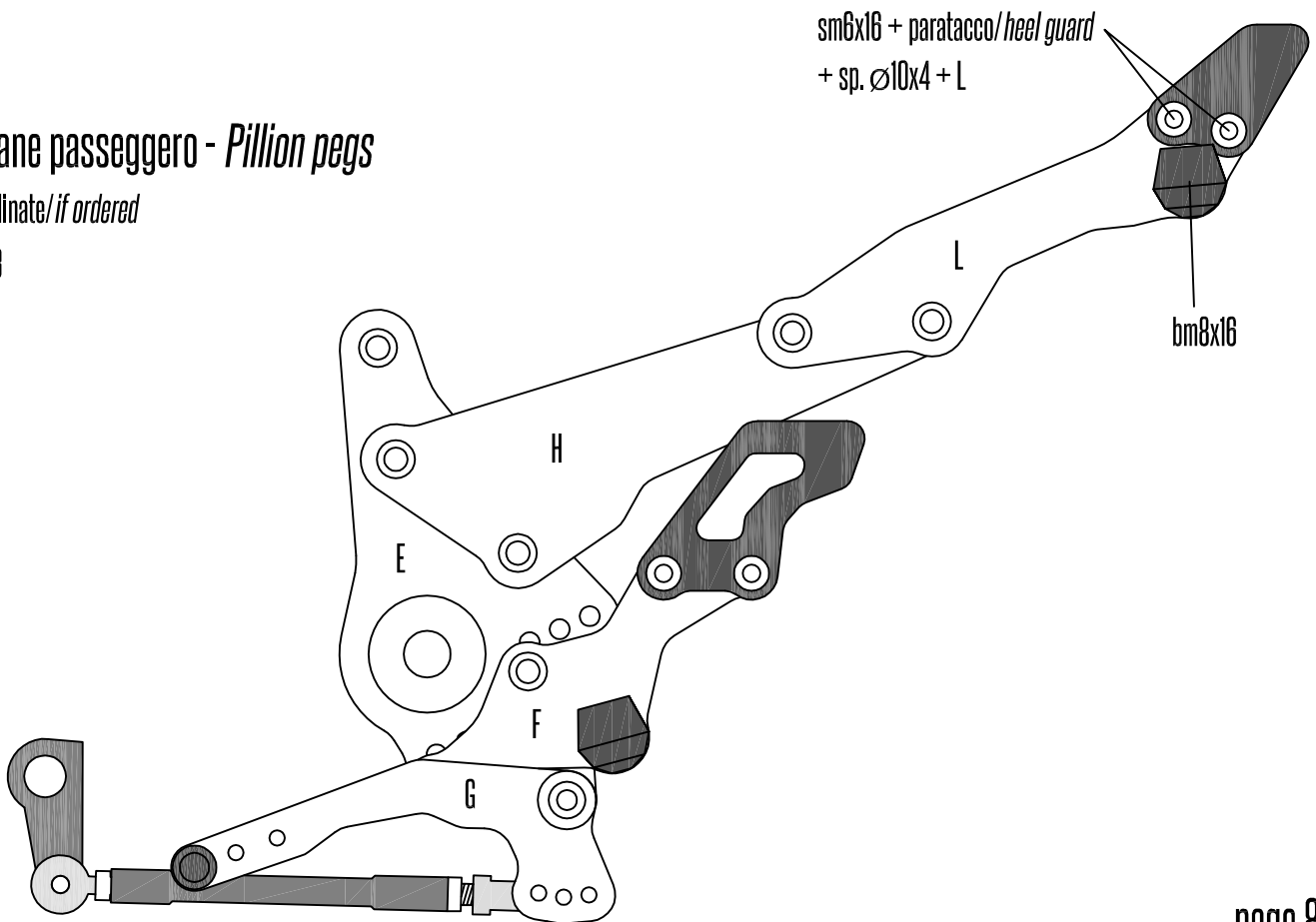

Ducati Monster 821, 1200 (2014-2016)

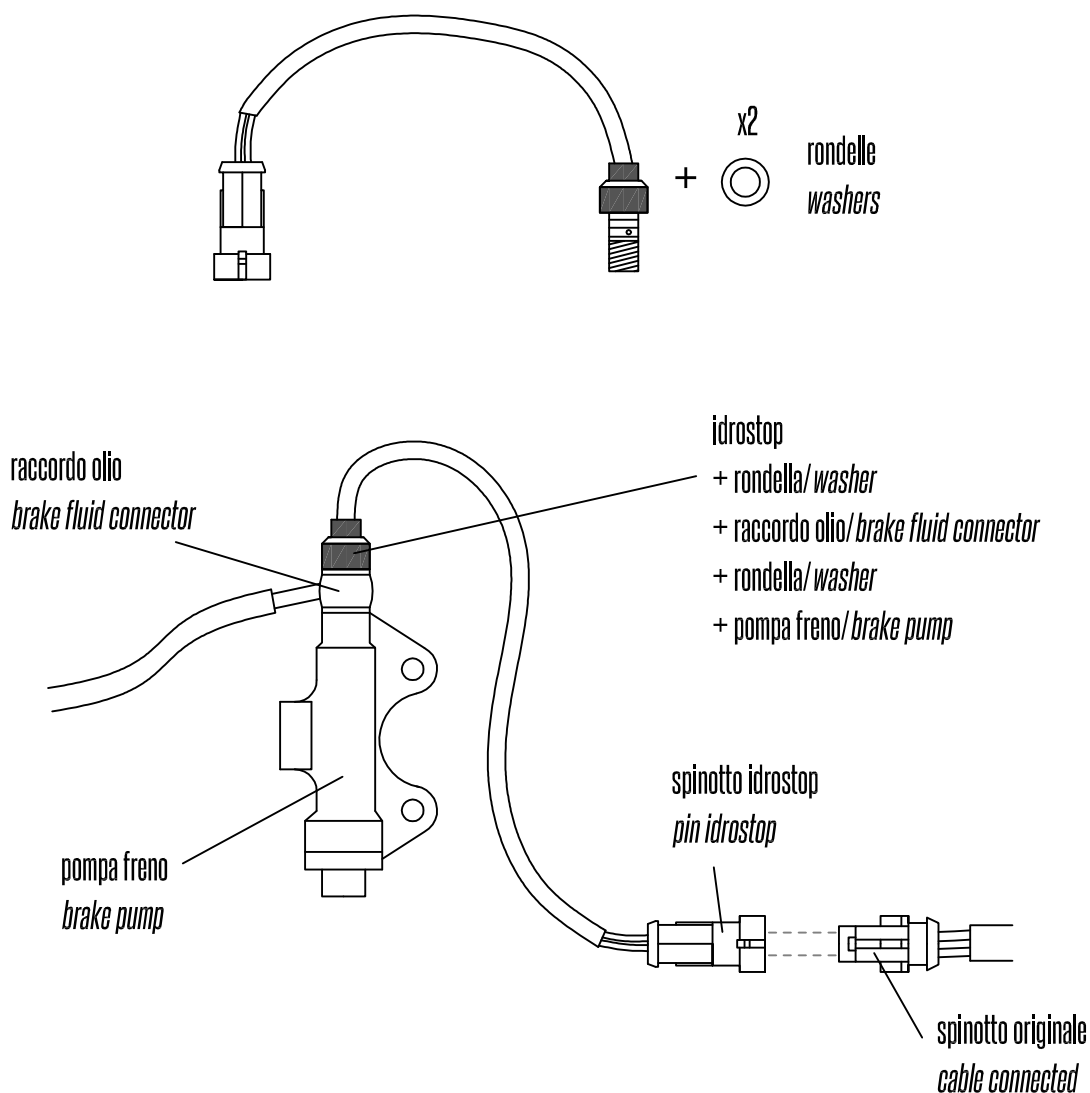

Su alcuni modelli di moto (es: MT-07 e Hornet >2007) lo spinotto originale è diverso da quello descritto nell'immagine.

Su altri modelli invece il cavo può risultare corto e non permette il collegamento con lo spinotto.

In questi due casi è necessario cablare i fili con l'idrostop per poterlo collegare, oppure usare altri fili come prolungha.

È consigliabile effettuare lo spurgo al termine del montaggio dell'idrostop, ma non è necessario se l'operazione viene effettuata correttamente.

For some models (ex: MT-07, Hornet >2007) the cable connected is different. In these case you need to cable the original one to connect on idrostop.

It's recommended to flush the brake fluid at the end of the idrostop mounting, but it's not necessary if the operation is successful.