

GeckoRacing

Honda Cbr 900, 929, 954 RR (2000-2003)

Lato freno - *Brake side*

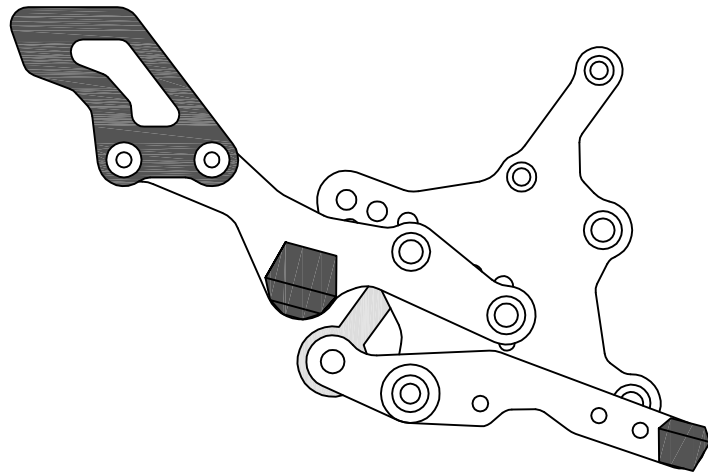

Lato cambio - *Gear side*

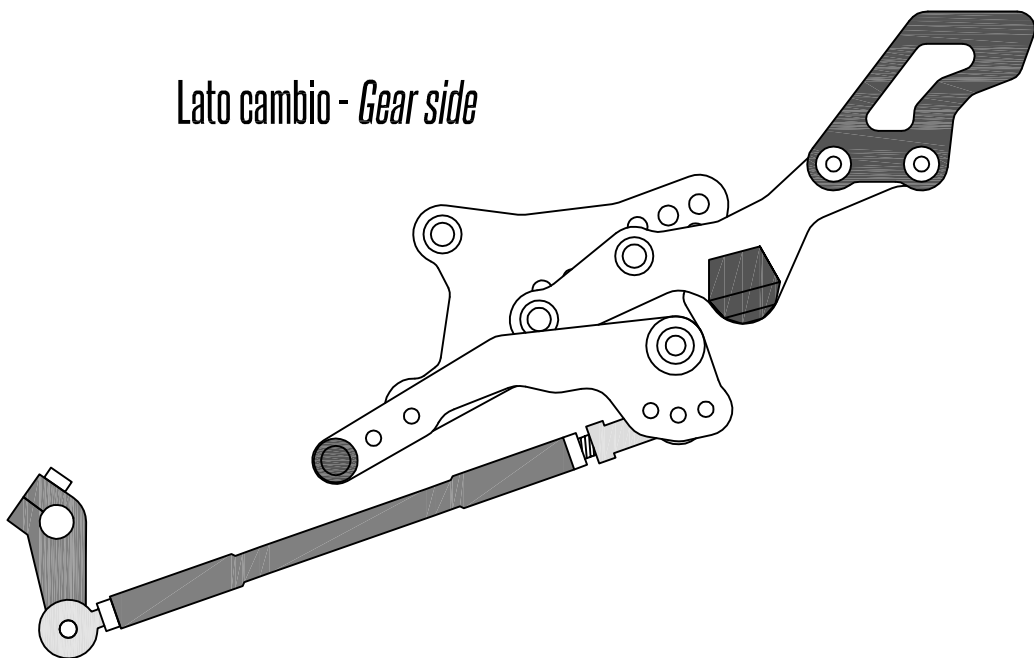

GeckoRacing

Honda Cbr 900, 929, 954 RR (2000-2003)

Bustina 1 - Bag 1

pedali poggiapiede - *footrest pegs*

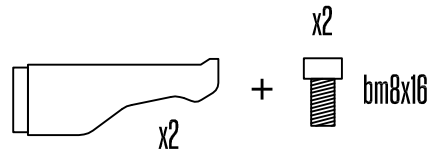

Bustina 2 - Bag 2

pedalini leve - *levers pedals*

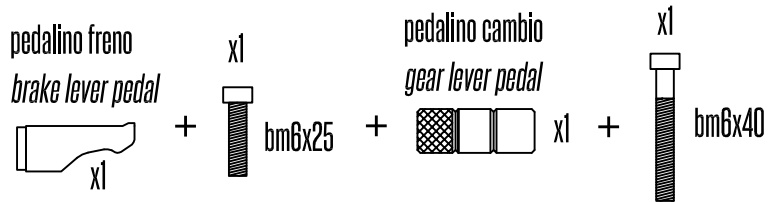

Bustina 3 - Bag 3

paratacchi - *heel guards*

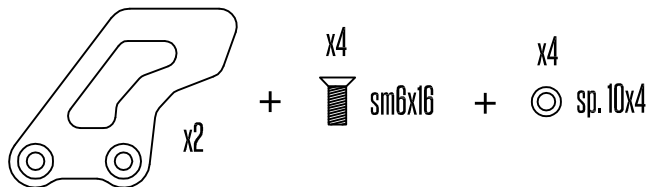

Bustina 4 - Bag 4

telaio - *frame*

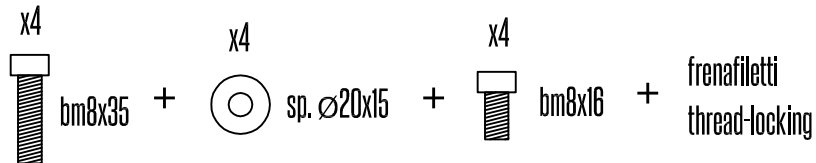

Bustina 5 - Bag 5

olio e cambio - *oil and gear*

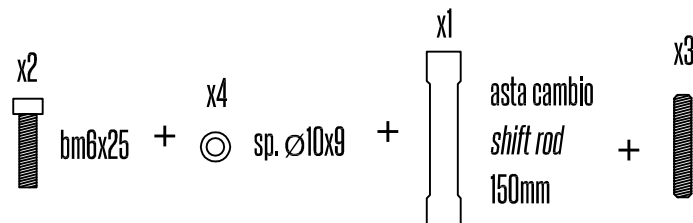

Idrostop

se ordinato - *if ordered*

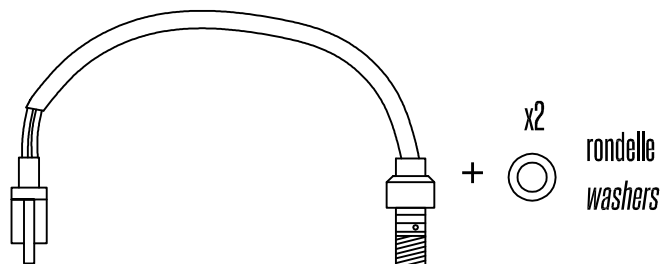

GeckoRacing

Honda Cbr 900, 929, 954 RR (2000-2003)

Lato freno - *Brake side*
step 1

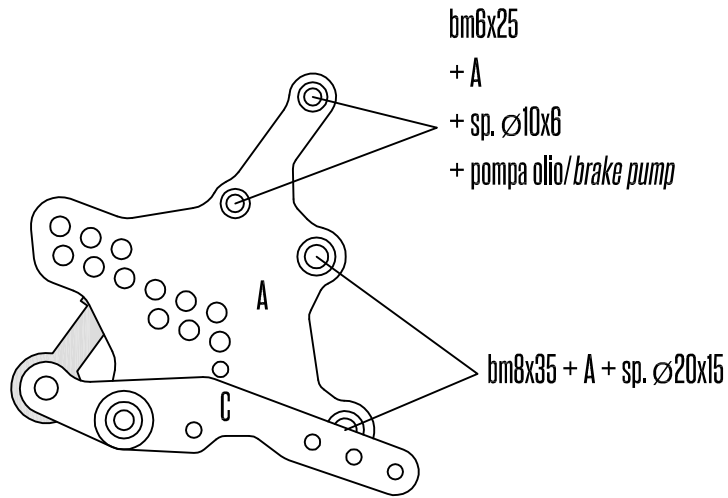

Lato freno - *Brake side*
step 2

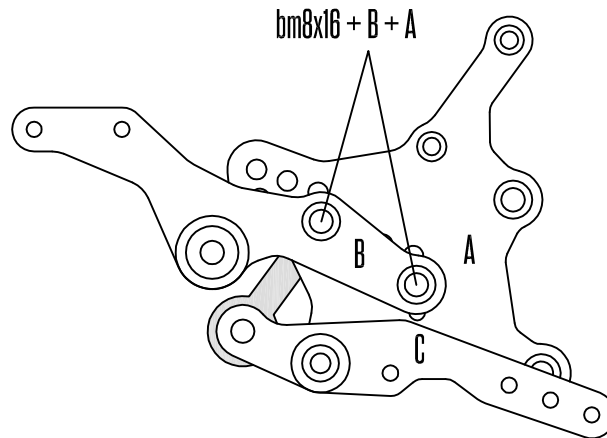

Lato freno - *Brake side*
step 3

sm6x16 + paratacco / heel guard + sp. $\varnothing 10 \times 4$ + B

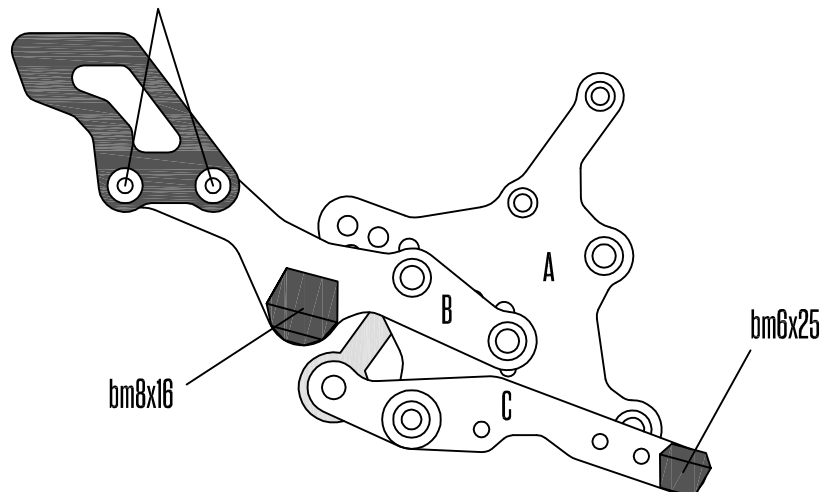

Honda Cbr 900, 929, 954 RR (2000-2003)

Lato cambio - *Gear side*

step 1

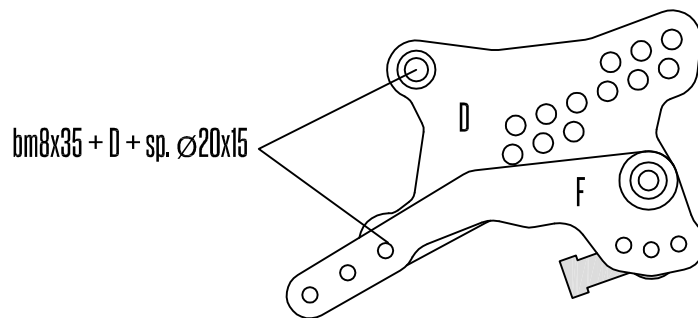

Lato cambio - *Gear side*

step 2

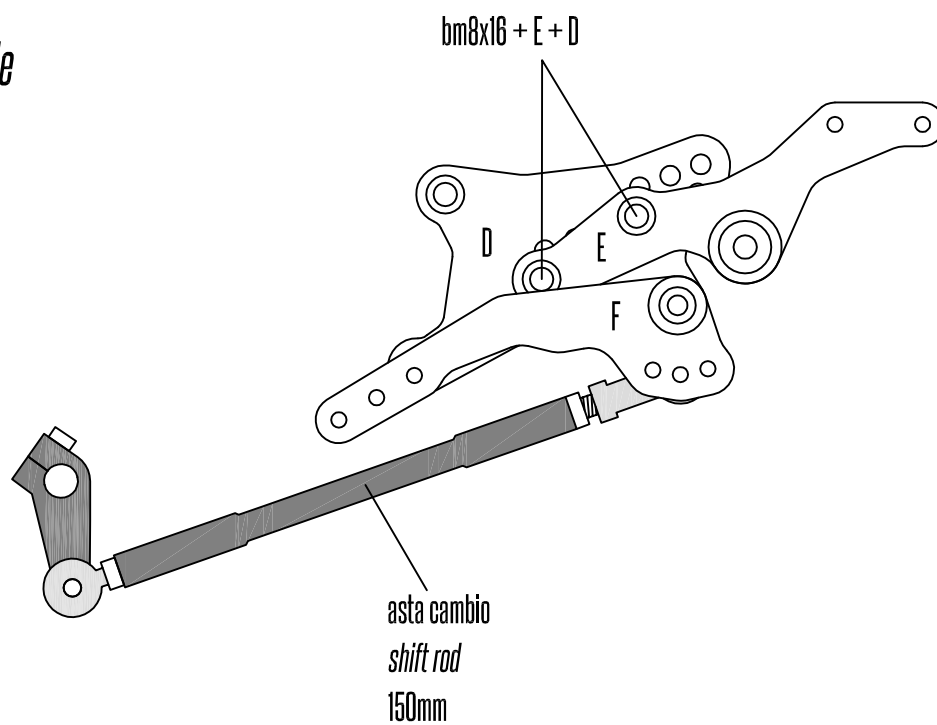

Honda Cbr 900, 929, 954 RR (2000-2003)

sm6x16 + paratacco/heel guard + sp. \varnothing 10x4 + C

Lato cambio - *Gear side*

step 3

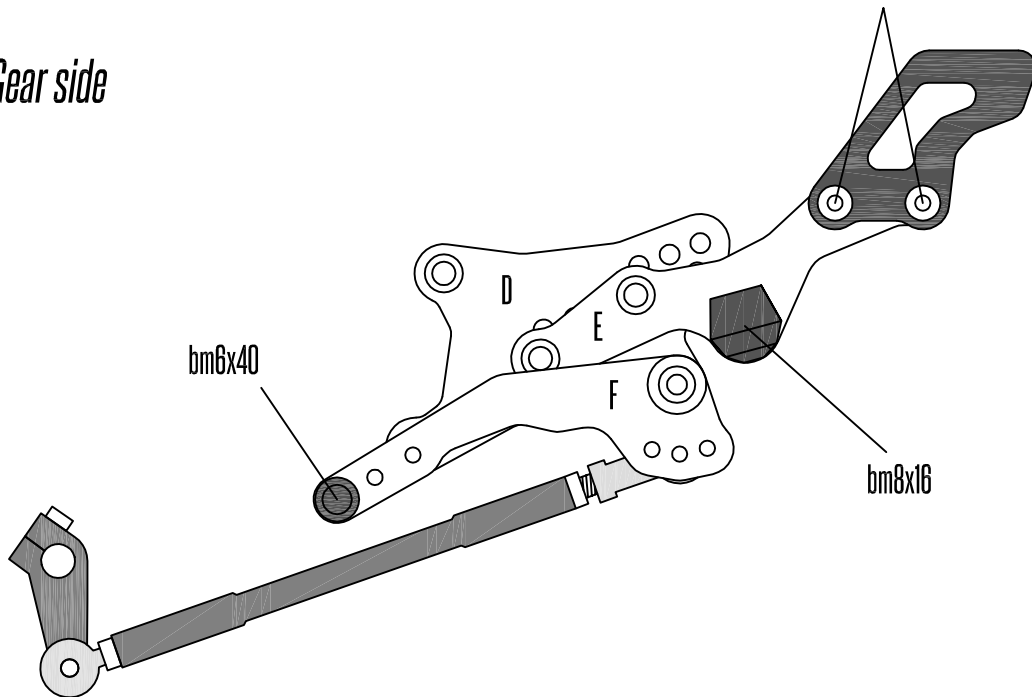

Cambio rovesciato - *Reverse gear*

ruotare il perno verso l'alto
turn upside up the chassis pin

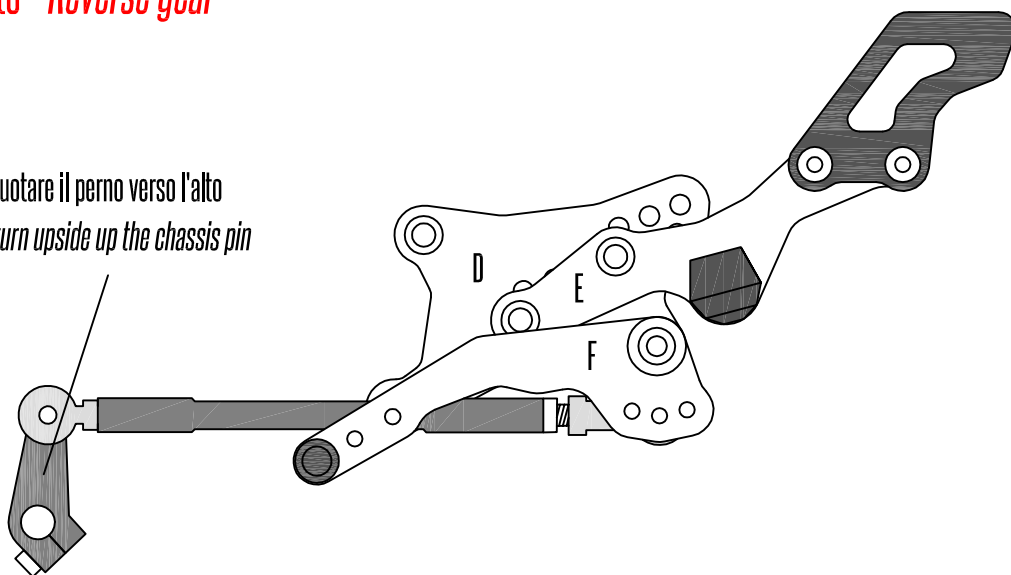

Honda Cbr 900, 929, 954 RR (2000-2003)

Idrostop

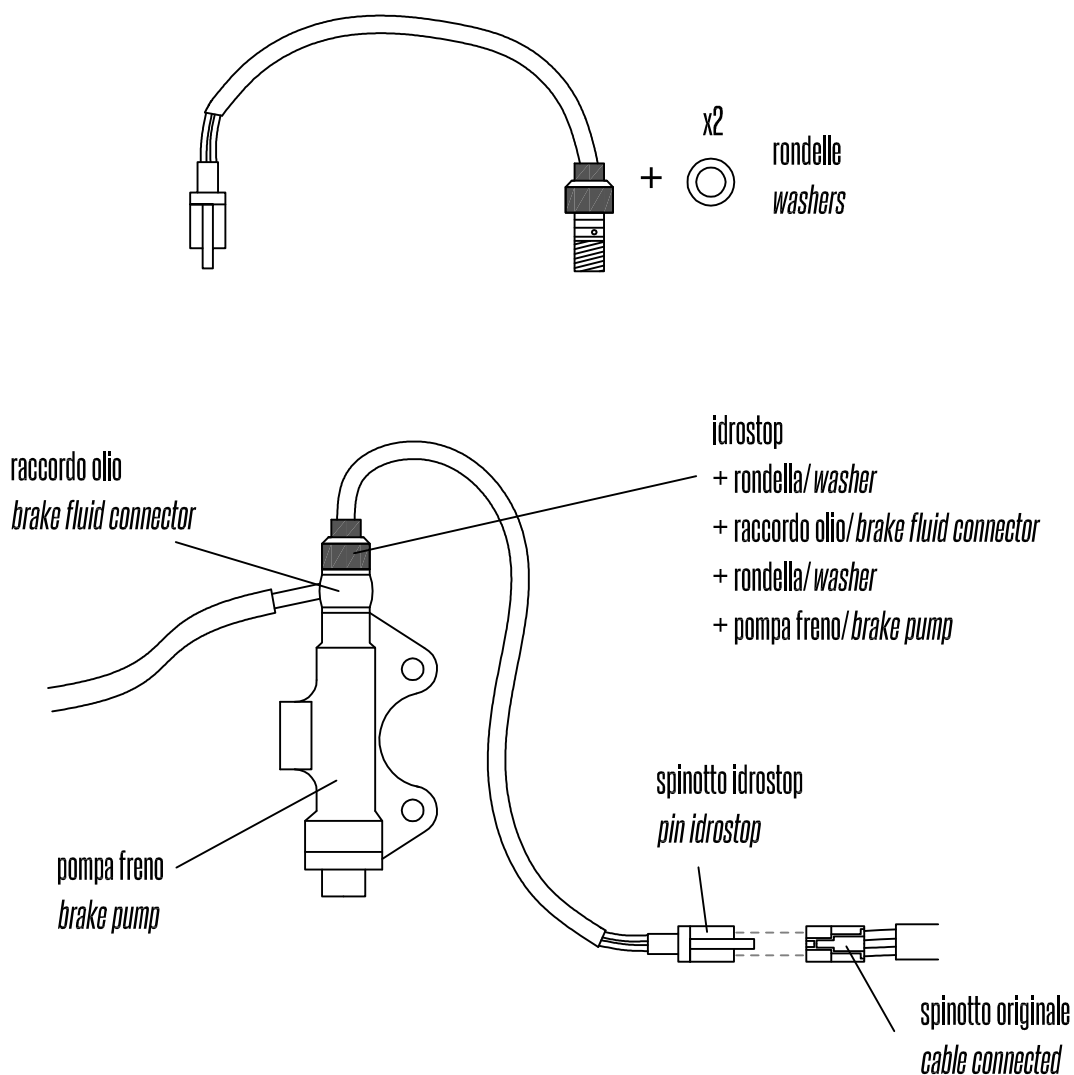

Su alcuni modelli di moto (es: Mt-07 e Hornet >2007) lo spinotto originale è diverso da quello descritto nell'immagine.

Su altri modelli invece il cavo può risultare corto e non permette il collegamento con lo spinotto.

In questi due casi è necessario cablare i fili con l'idrostop per poterlo collegare, oppure usare altri fili come prolungha.

È consigliabile effettuare lo spurgo al termine del montaggio dell'idrostop, ma non è necessario se l'operazione viene effettuata correttamente.

For some models (ex: MT-07, Hornet >2007) the cable connected is different. In these case you need to cable the original one to connect on idrostop.

It's recommended to flush the brake fluid at the end of the idrostop mounting, but it's not necessary if the operation is successful.