

GeckoRacing

Kawasaki Z800

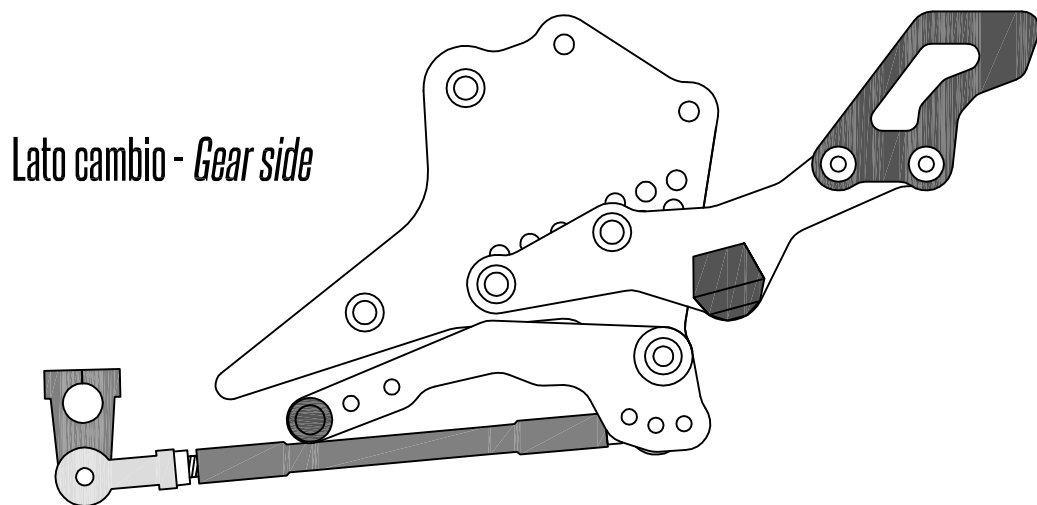
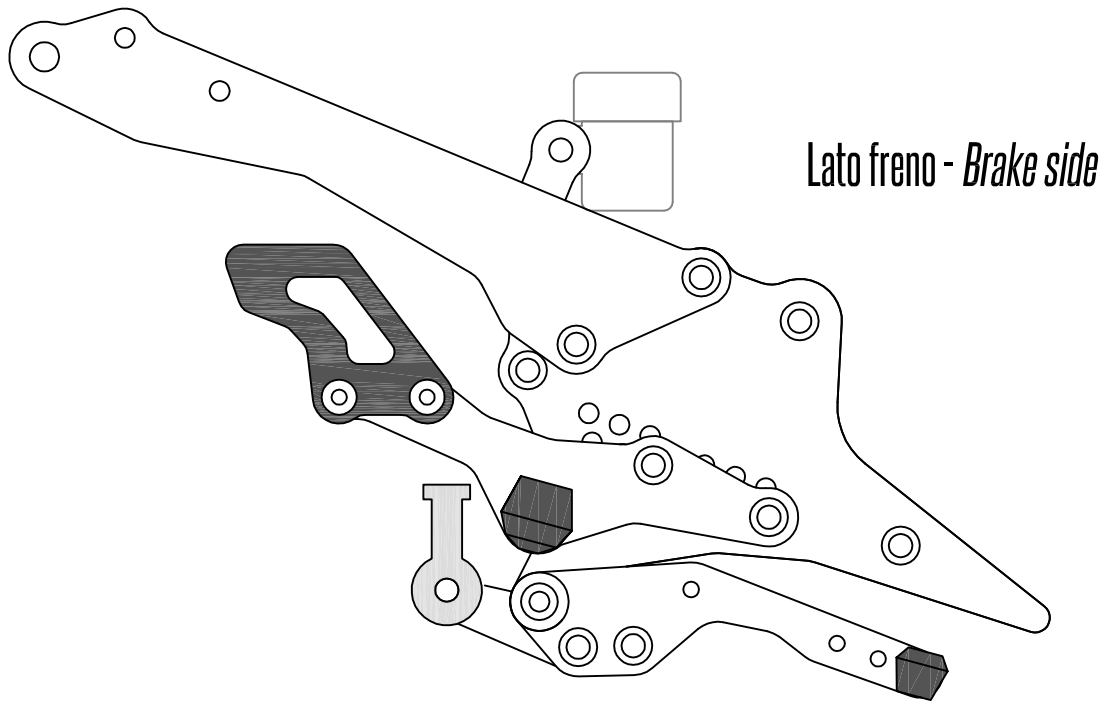

GeckoRacing

Kawasaki Z800

Bustina 1 - Bag 1 - (x2 con pedane passeggero | x2 with pillion pegs)

pedali poggiapiede - footrest pegs

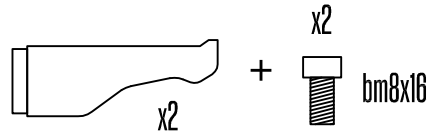

Bustina 2 - Bag 2

pedalini leve - levers pedals

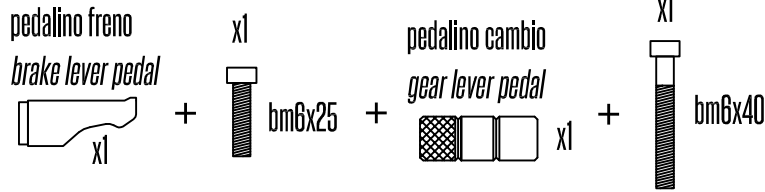

Bustina 3 - Bag 3

paratacchi - heel guards

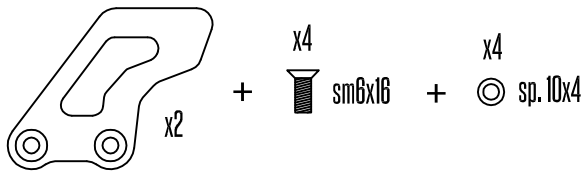

Bustina 4 - Bag 4

telaio - frame

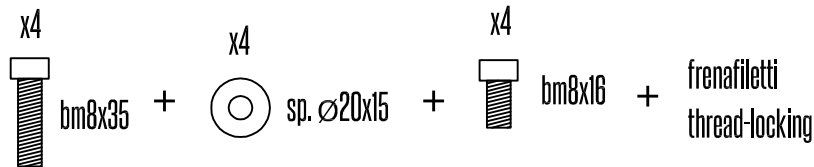

Bustina 5 - Bag 5

pompa olio - oil pump

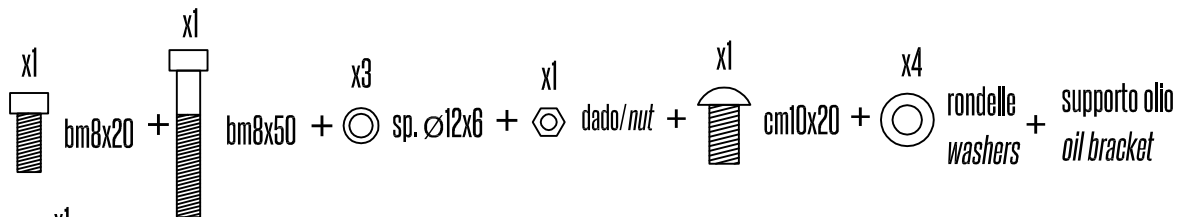

Bustina 6 - Bag 6

cambio - gear

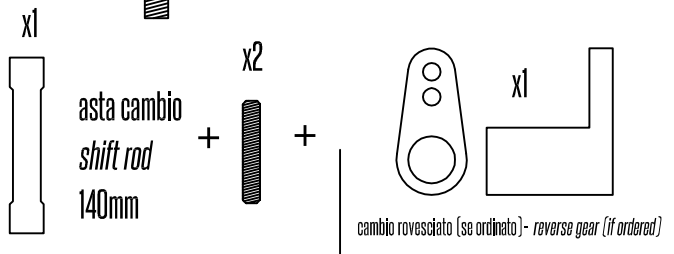

Bustina 7 - Bag 7

staffa scarico-pedane passeggero
bracket exhaust-pillion pegs

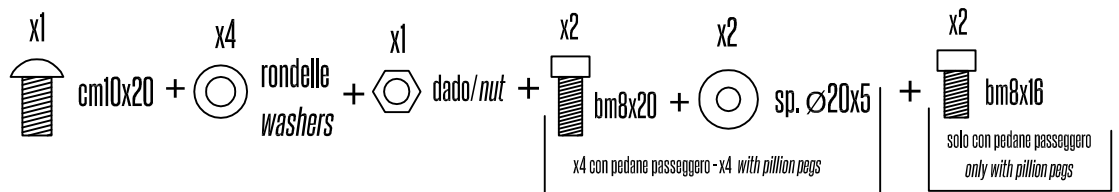

Bustina 8 - Bag 8

paratacchi per pedane passeggero - heel guards on pillion pegs

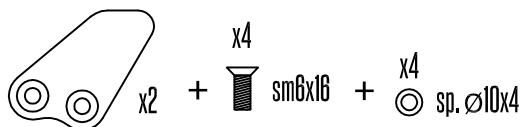

Idrostop

se ordinato - if ordered

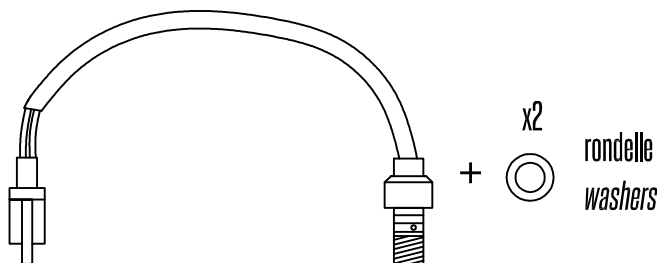

GeckoRacing

Kawasaki Z800

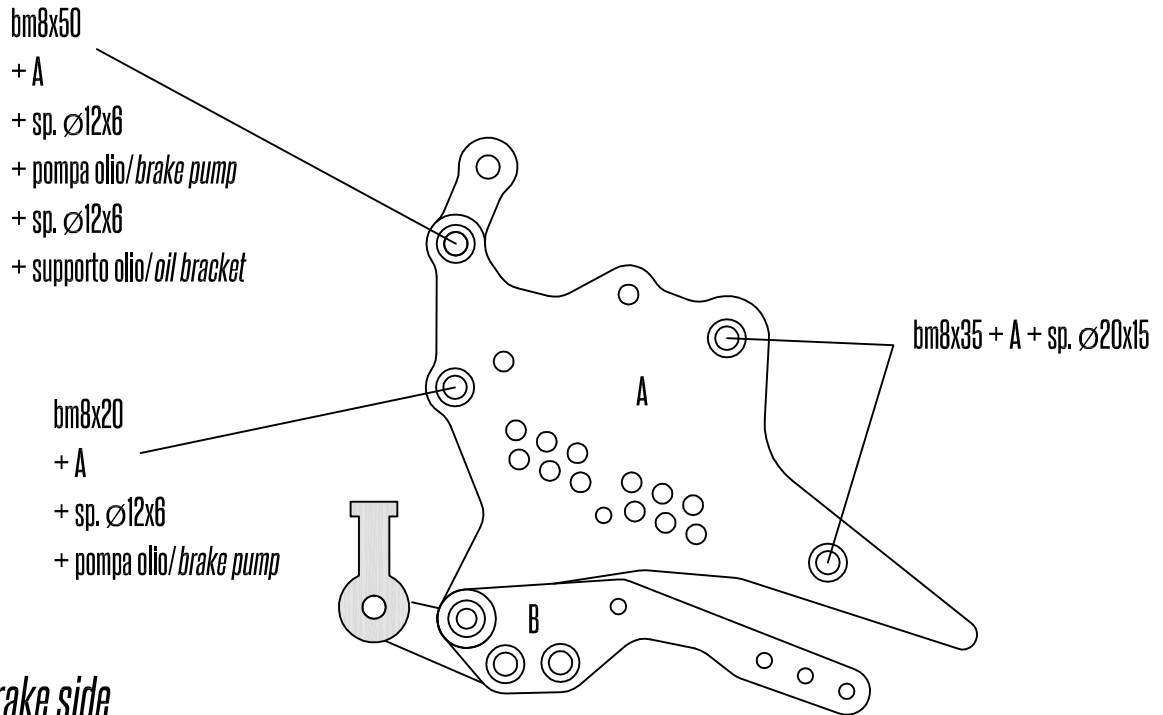

Lato freno - Brake side

step 1

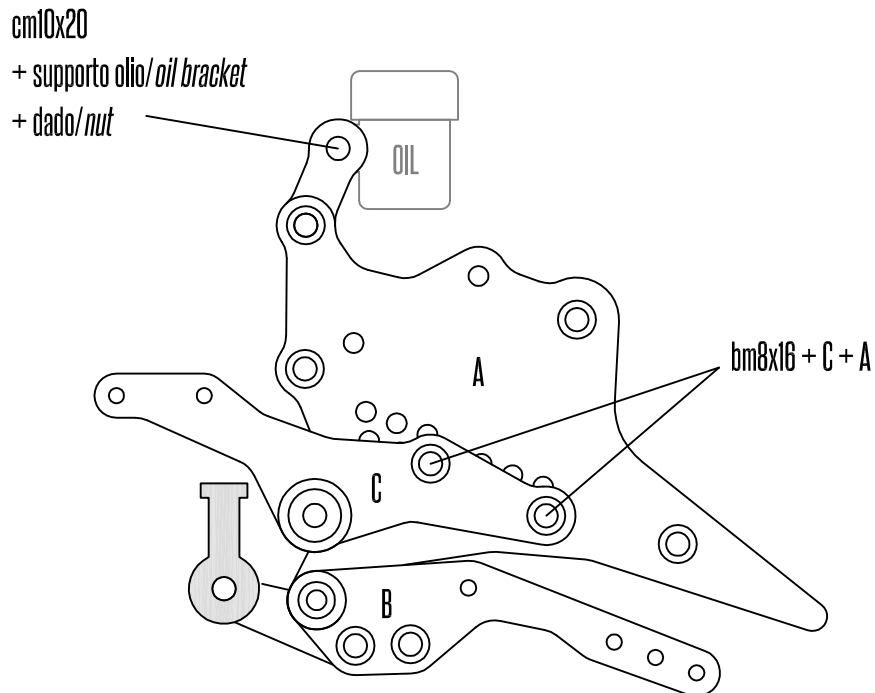

Lato freno - Brake side

step 2

GeckoRacing

Kawasaki Z800

cm10x20 + P + scarico/exhausts + dado/nut

bm8x20 + P + sp. \varnothing 20x5 + A

P

OIL

A

C

B

Lato freno - *Brake side*
step 3

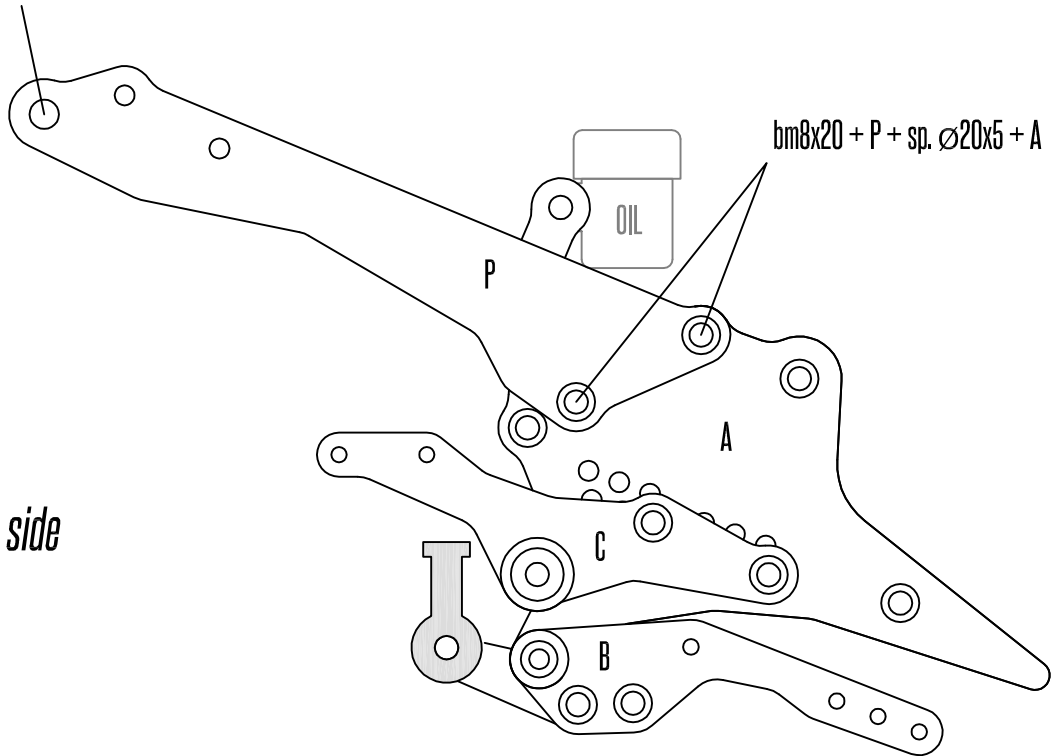

sm6x16 + paratacco/heel guard + sp. \varnothing 10x4 + P

OIL

P

A

C

B

Lato freno - *Brake side*
step 4

bm8x16

bm6x25

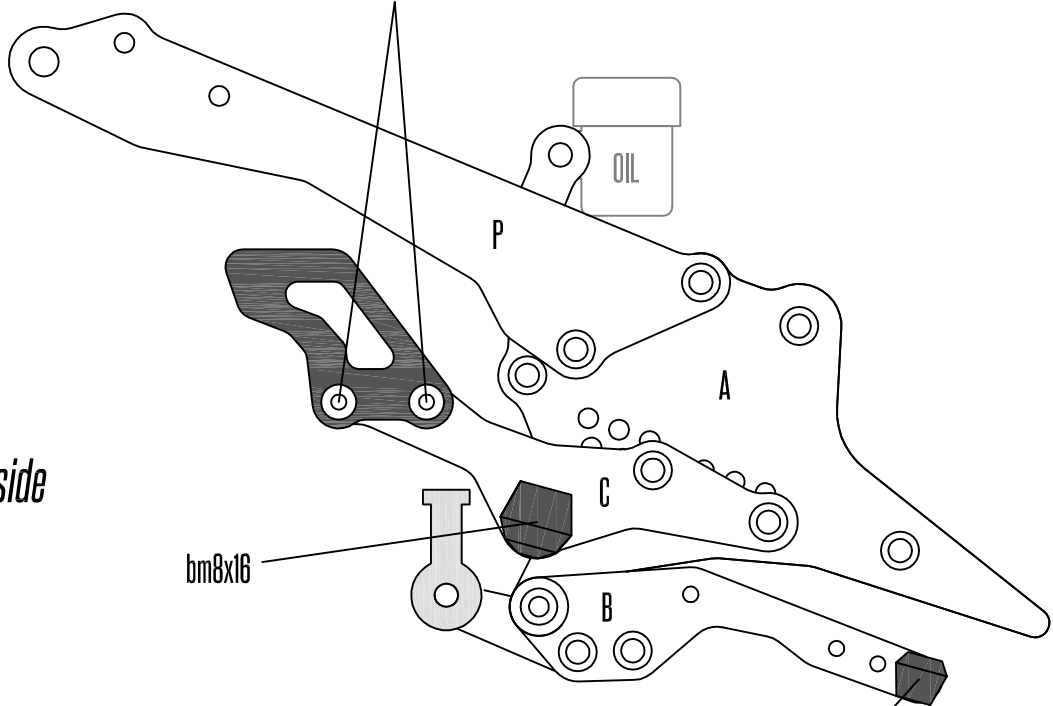

GeckoRacing

Kawasaki Z800

Lato cambio
Gear side
step 1

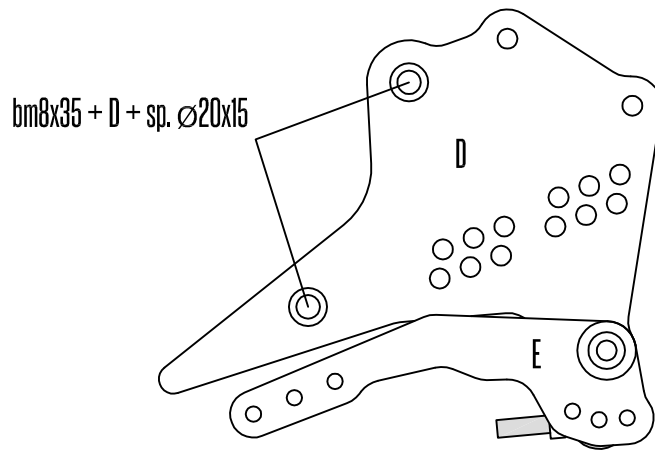

Lato cambio
Gear side
step 2

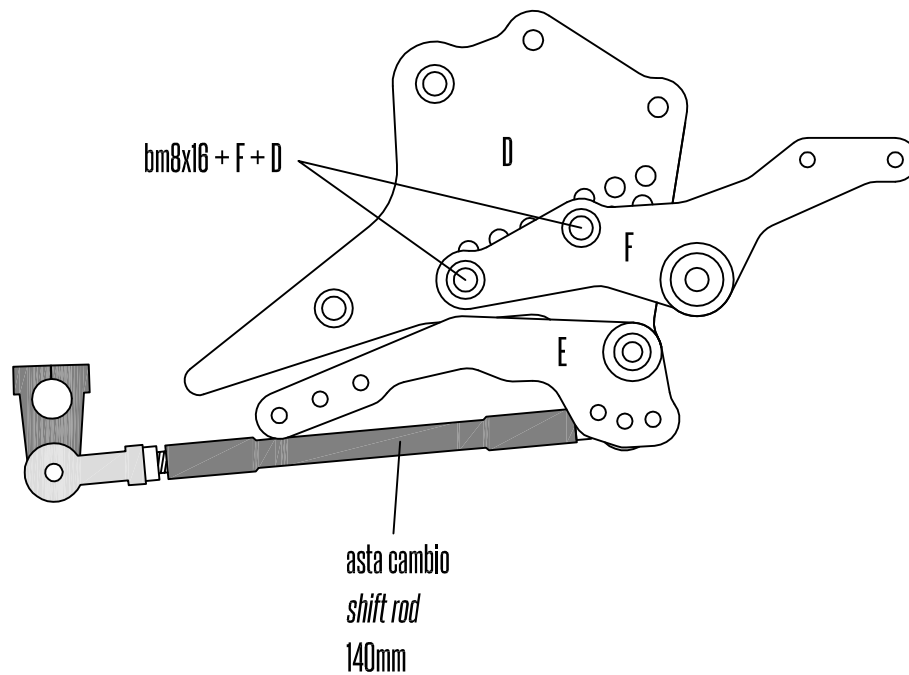

GeckoRacing

Kawasaki Z800

Lato cambio
Gear side
step 3

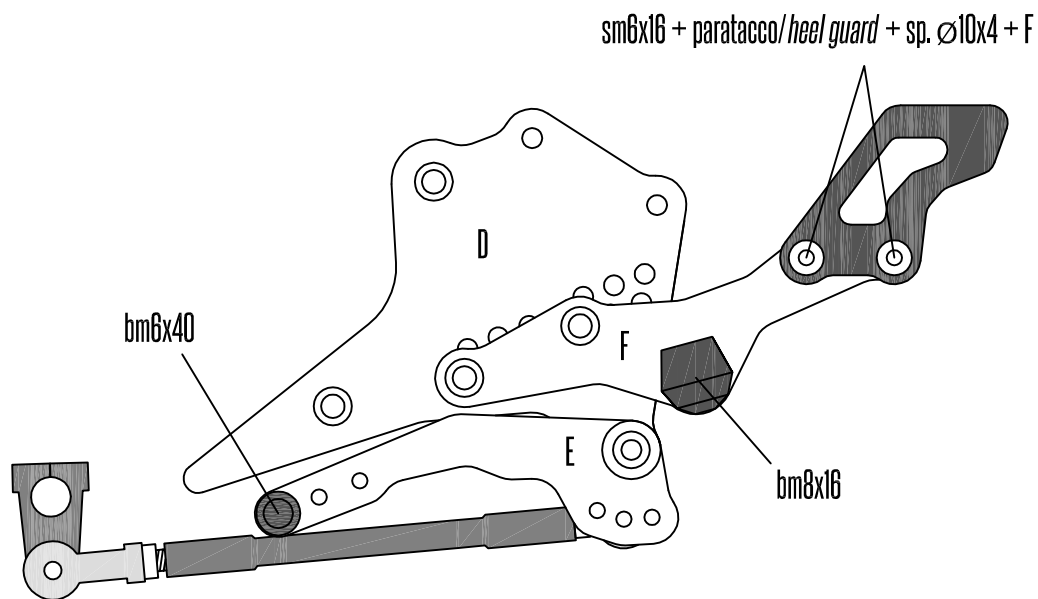

Cambio rovesciato
(se ordinato)

Reverse gear
(if ordered)

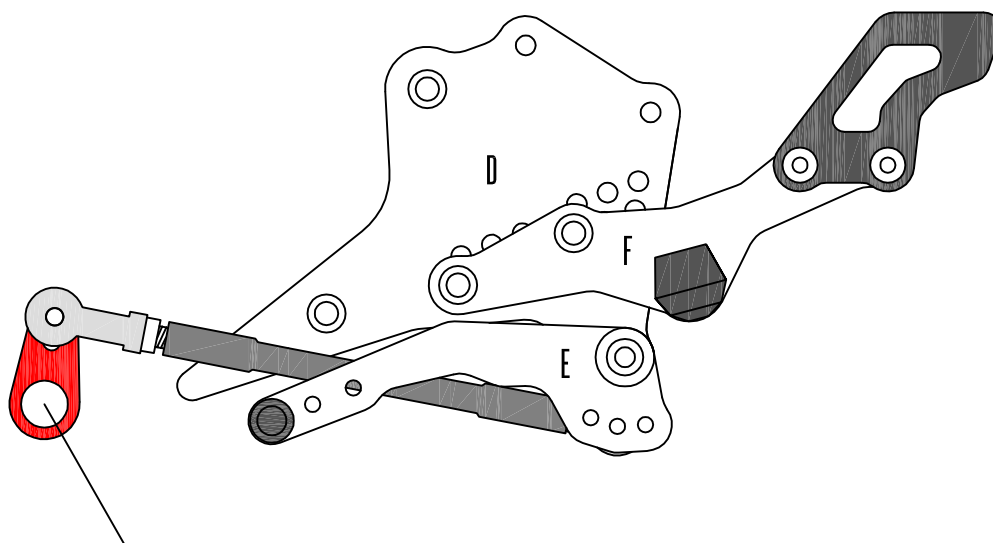

montare il nuovo perno per il cambio rovesciato rivolto verso l'alto
mount the new bracket for reverse gear and turn it upside up

GeckoRacing

Kawasaki Z800

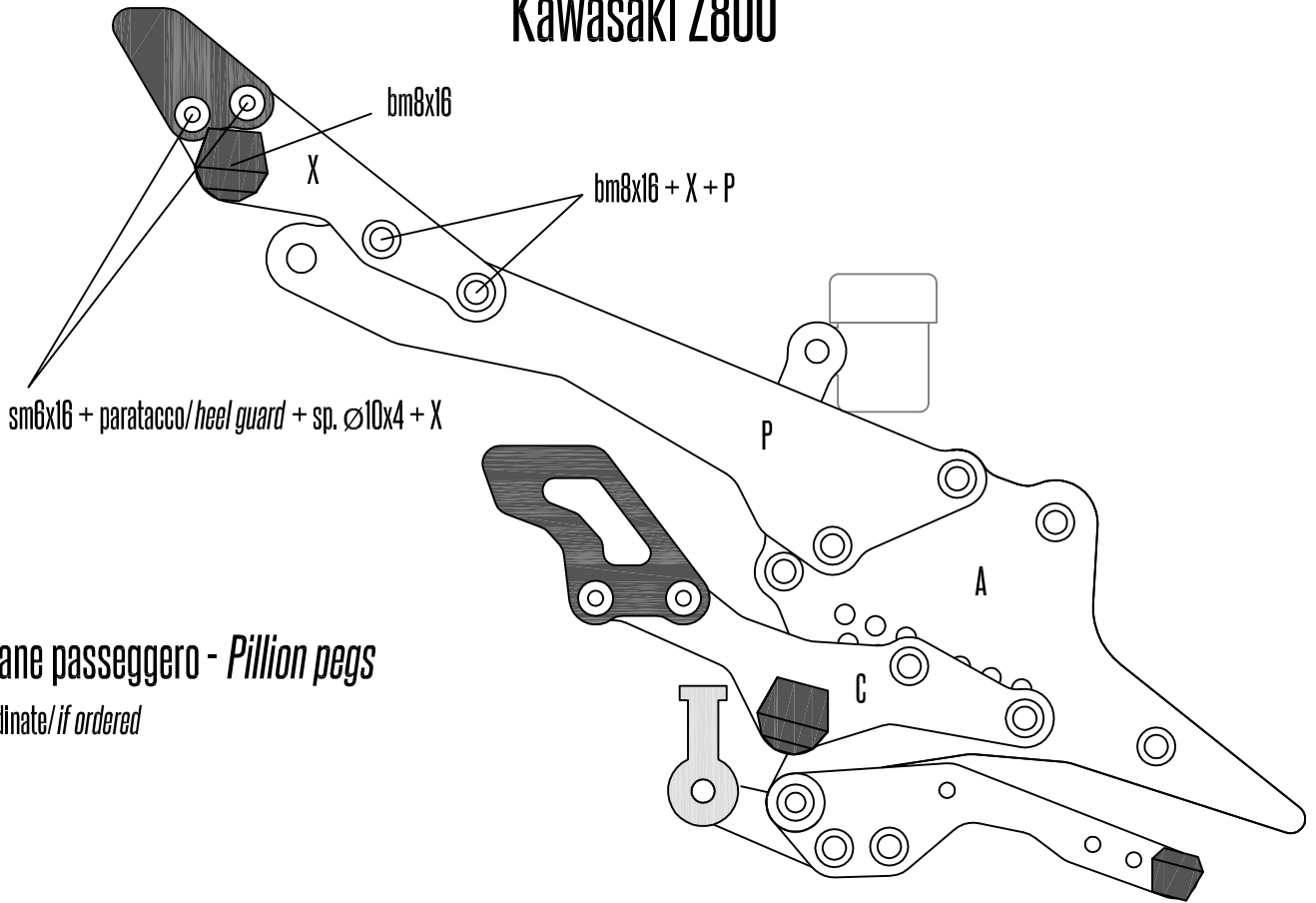

Pedane passeggero - Pillion pegs

se ordinate/ if ordered

step 1

sm6x16 + paratacco/heel guard + sp. Ø10x4 + P

Pedane passeggero - Pillion pegs

se ordinate/ if ordered

step 2

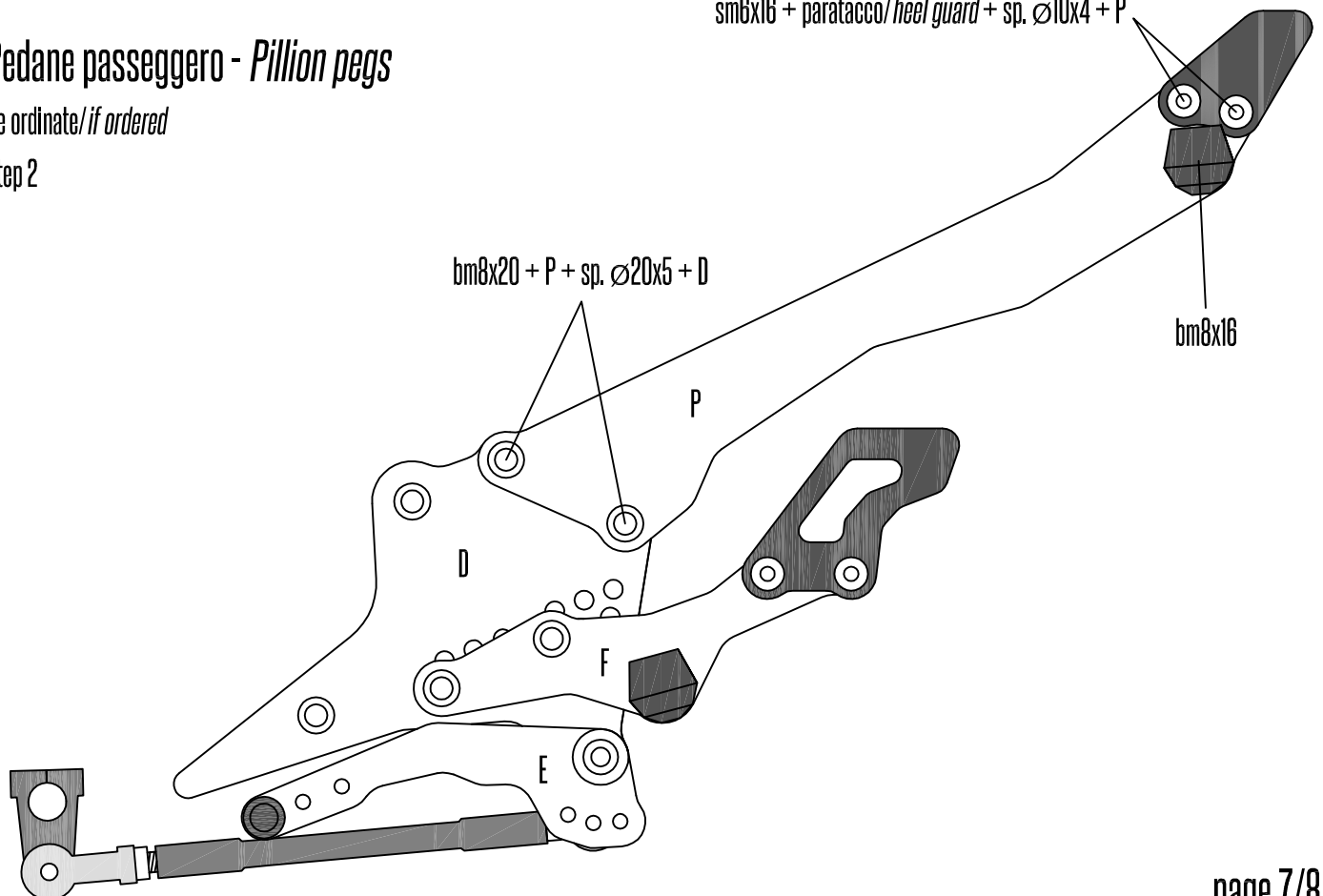

GeckoRacing

Kawasaki Z800

Idrostop

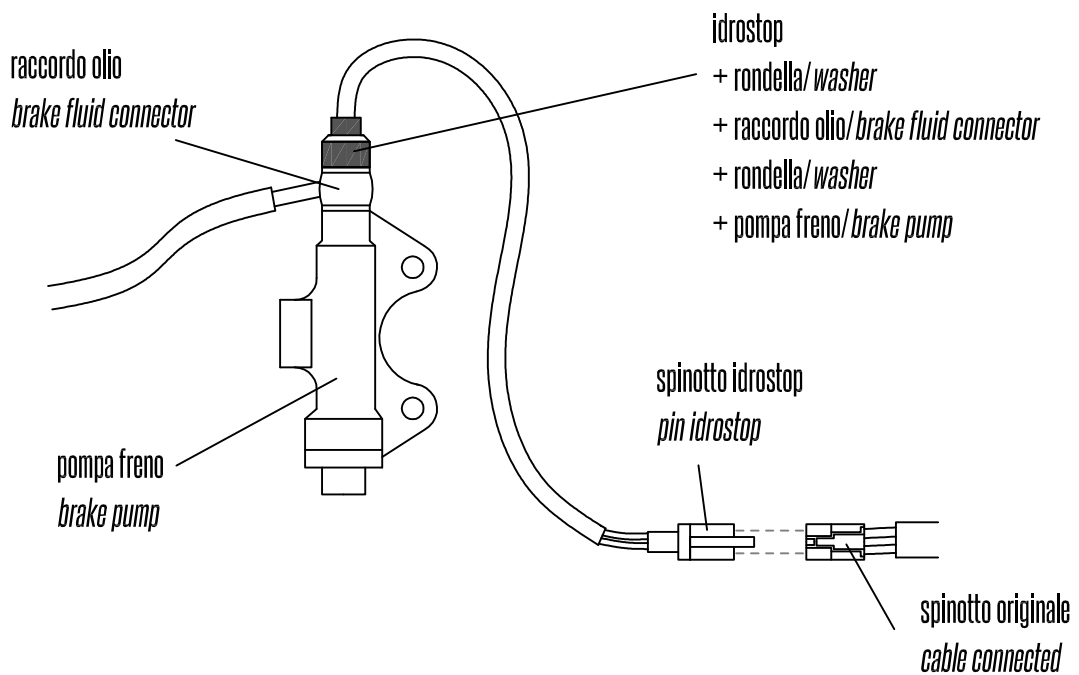
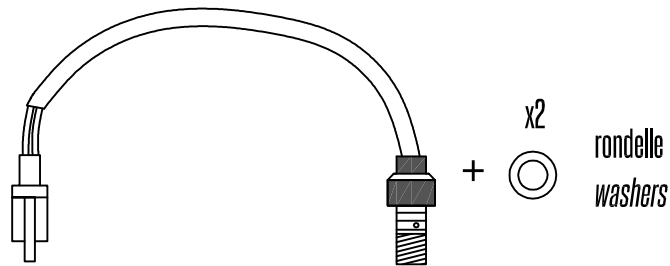

Su alcuni modelli di moto (es: Mt-07 e Hornet >2007) lo spinotto originale è diverso da quello descritto nell'immagine.

Su altri modelli invece il cavo può risultare corto e non permette il collegamento con lo spinotto.

In questi due casi è necessario cablare i fili con l'idrostop per poterlo collegare, oppure usare altri fili come prolungha.

È consigliabile effettuare lo spurgo al termine del montaggio dell'idrostop, ma non è necessario se l'operazione viene effettuata correttamente.

For some models (ex: MT-07, Hornet>2007) the cable connected is different. In these case you need to cable the original one to connect on idrostop.

It's recommended to flush the brake fluid at the end of the idrostop mounting, but it's not necessary if the operation is successful.