

Suzuki Gsx-R 600 (2006-2010)

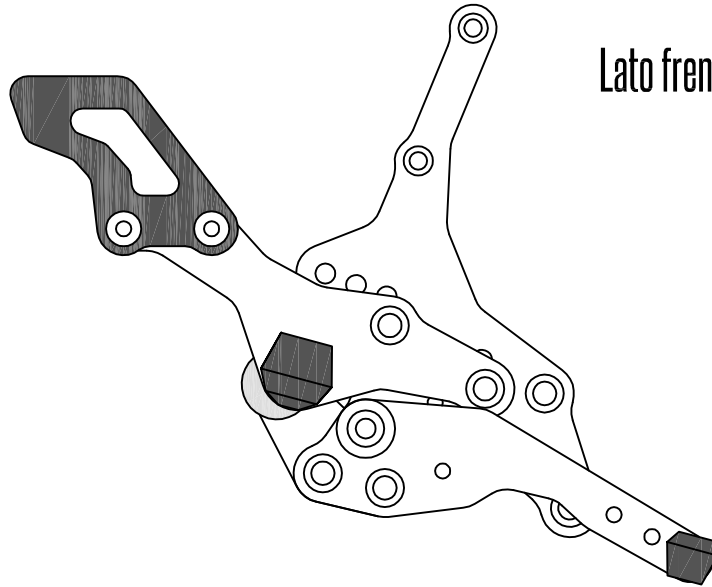

Lato freno - *Brake side*

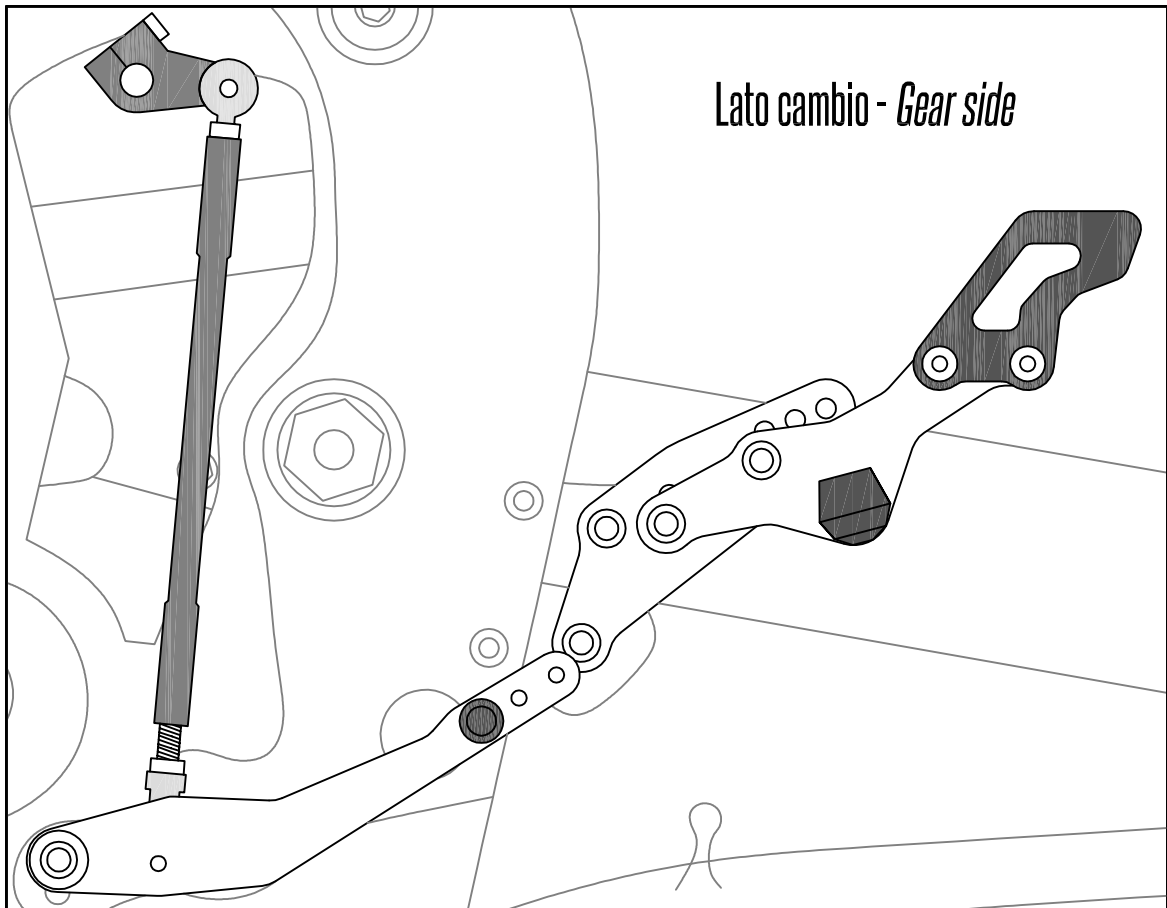

Lato cambio - *Gear side*

GeckoRacing

Suzuki Gsx-R 600 (2006-2010)

Bustina 1 - Bag 1

pedali poggiapiede - footrest pegs

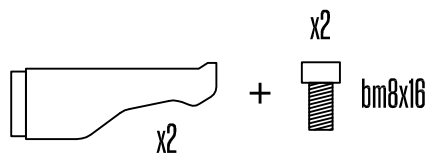

Bustina 2 - Bag 2

pedalini leve - levers pedals

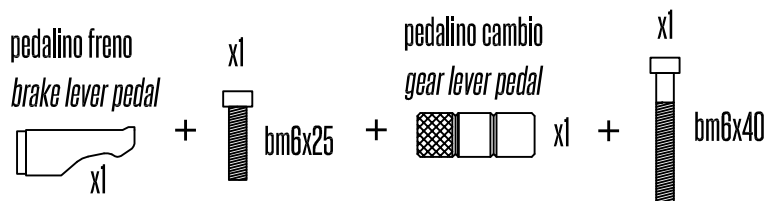

Bustina 3 - Bag 3

paratacchi - heel guards

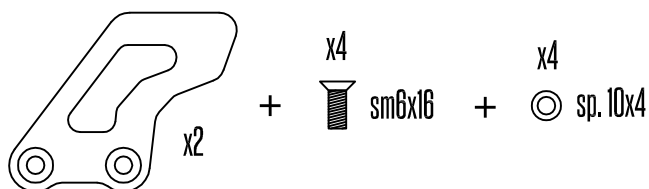

Bustina 4 - Bag 4

telaio - frame

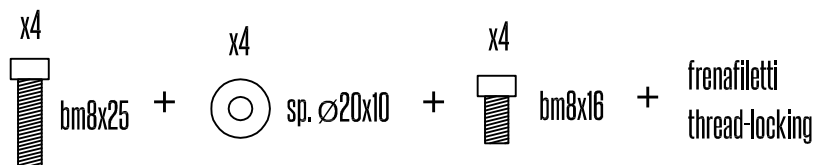

Bustina 5 - Bag 5

pompa olio e cambio - oil pump and gear

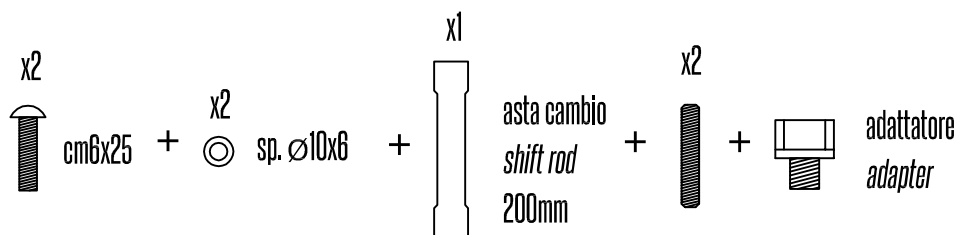

Idrostop

se ordinato - if ordered

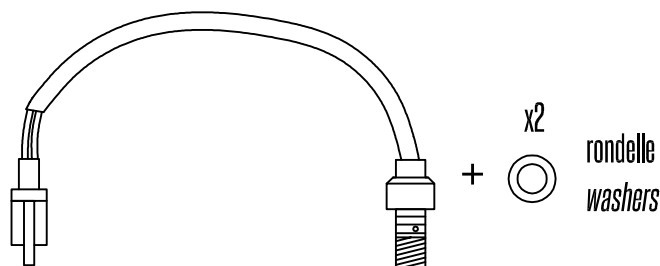

GeckoRacing

Suzuki Gsx-R 600 (2006-2010)

Lato freno - *Brake side*
step 1

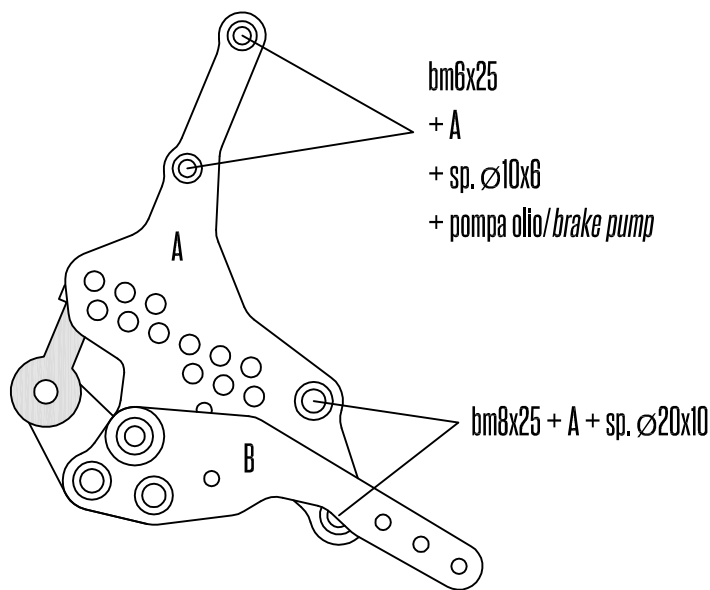

Lato freno - *Brake side*
step 2

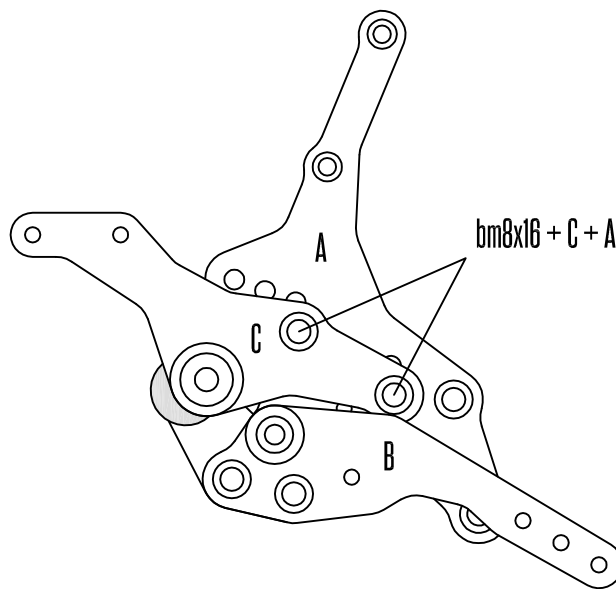

Lato freno - *Brake side*
step 3

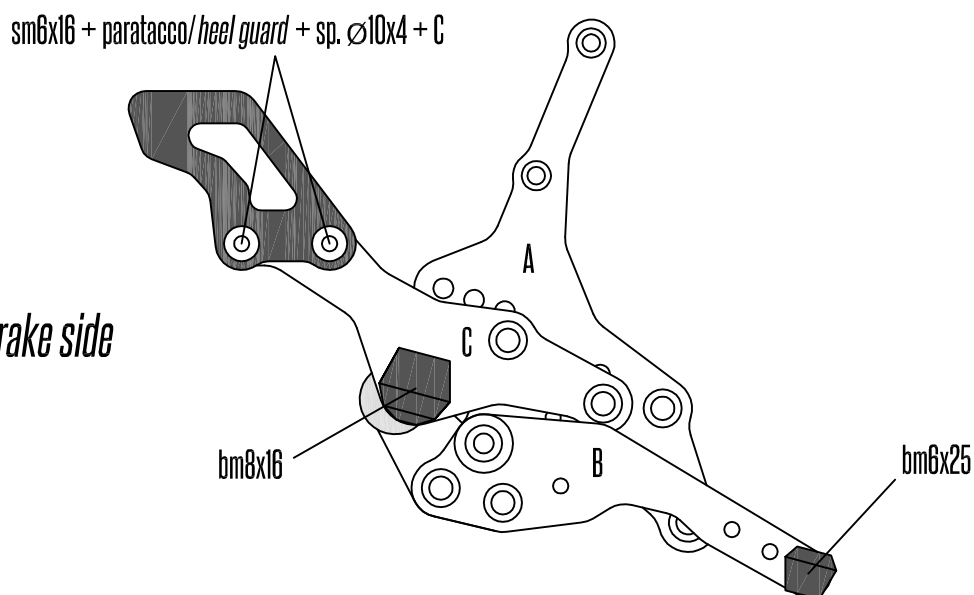

Suzuki Gsx-R 600 (2006-2010)

Lato cambio
Gear side
step 1

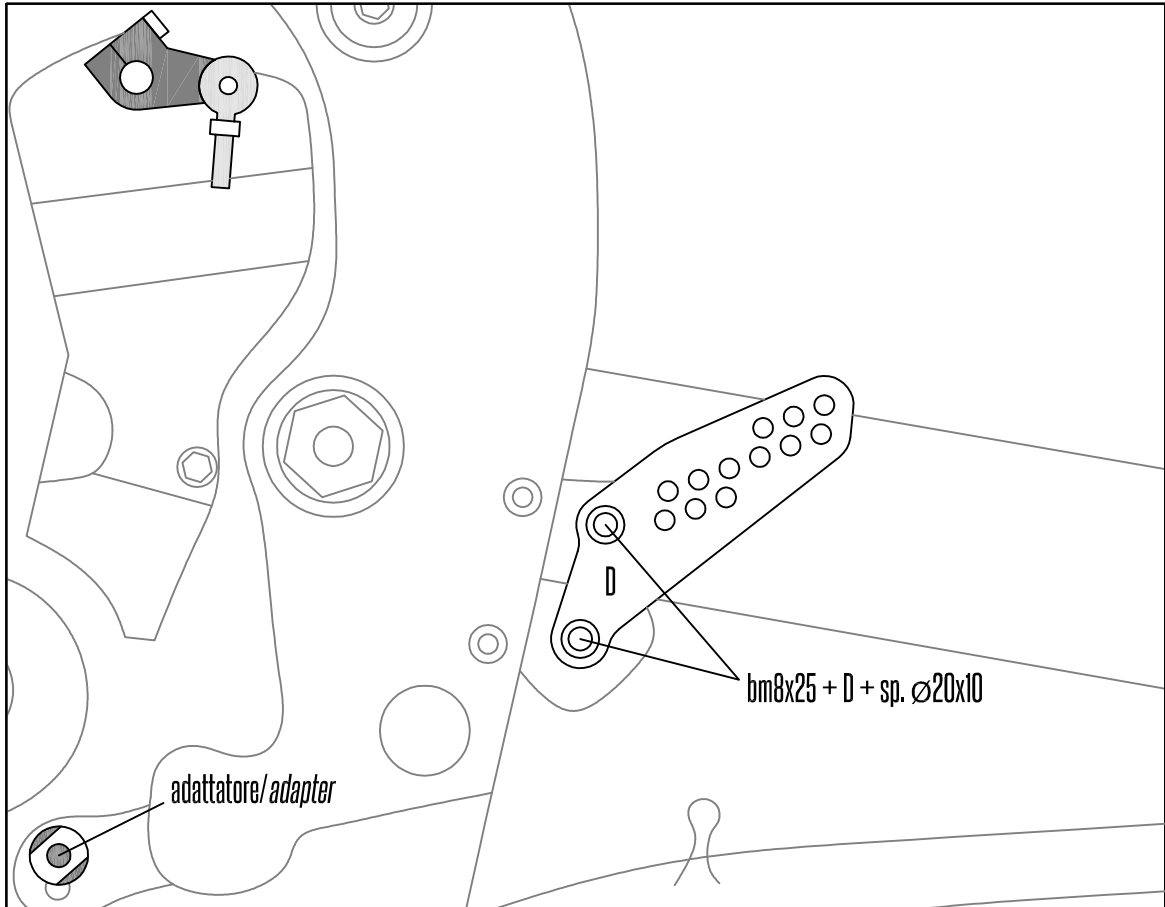

Lato cambio
Gear side
step 2

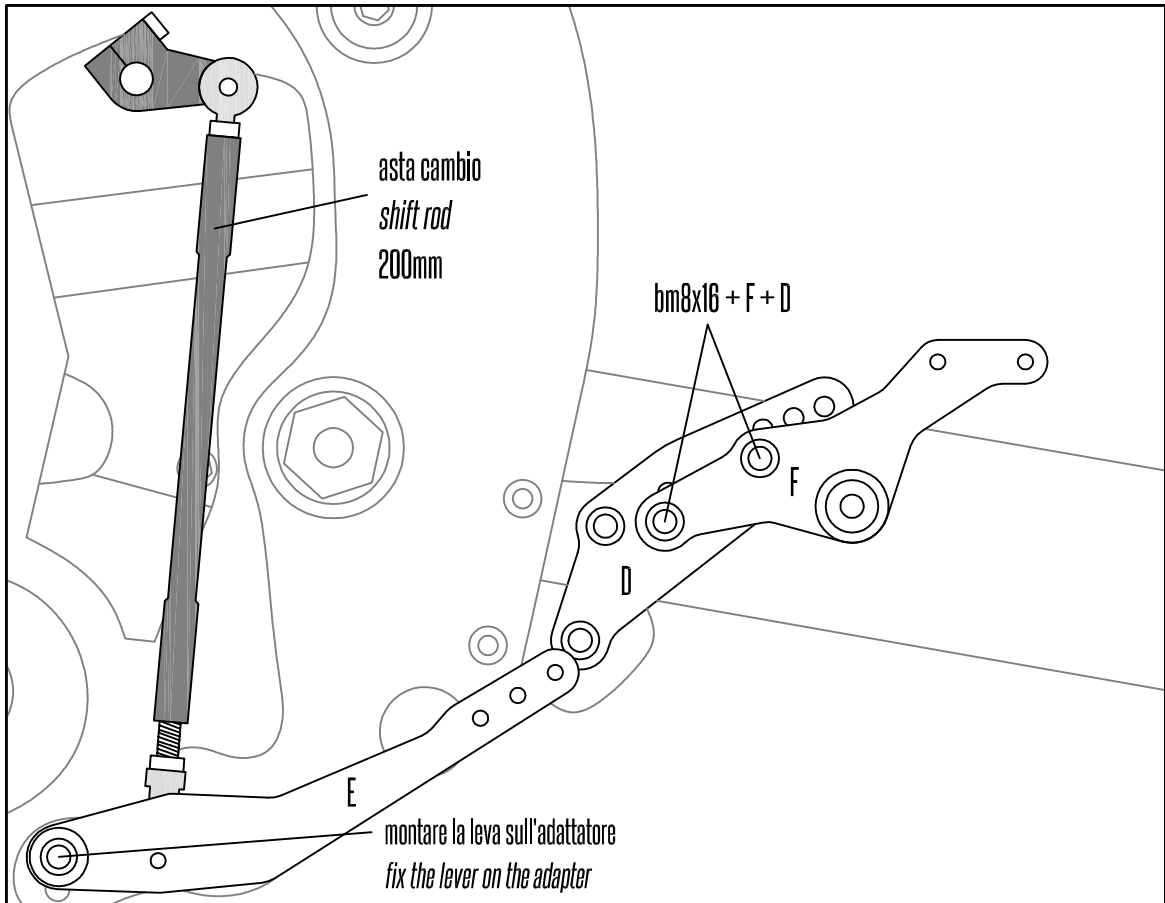

Suzuki Gsx-R 600 (2006-2010)

Lato cambio
Gear side
step 3

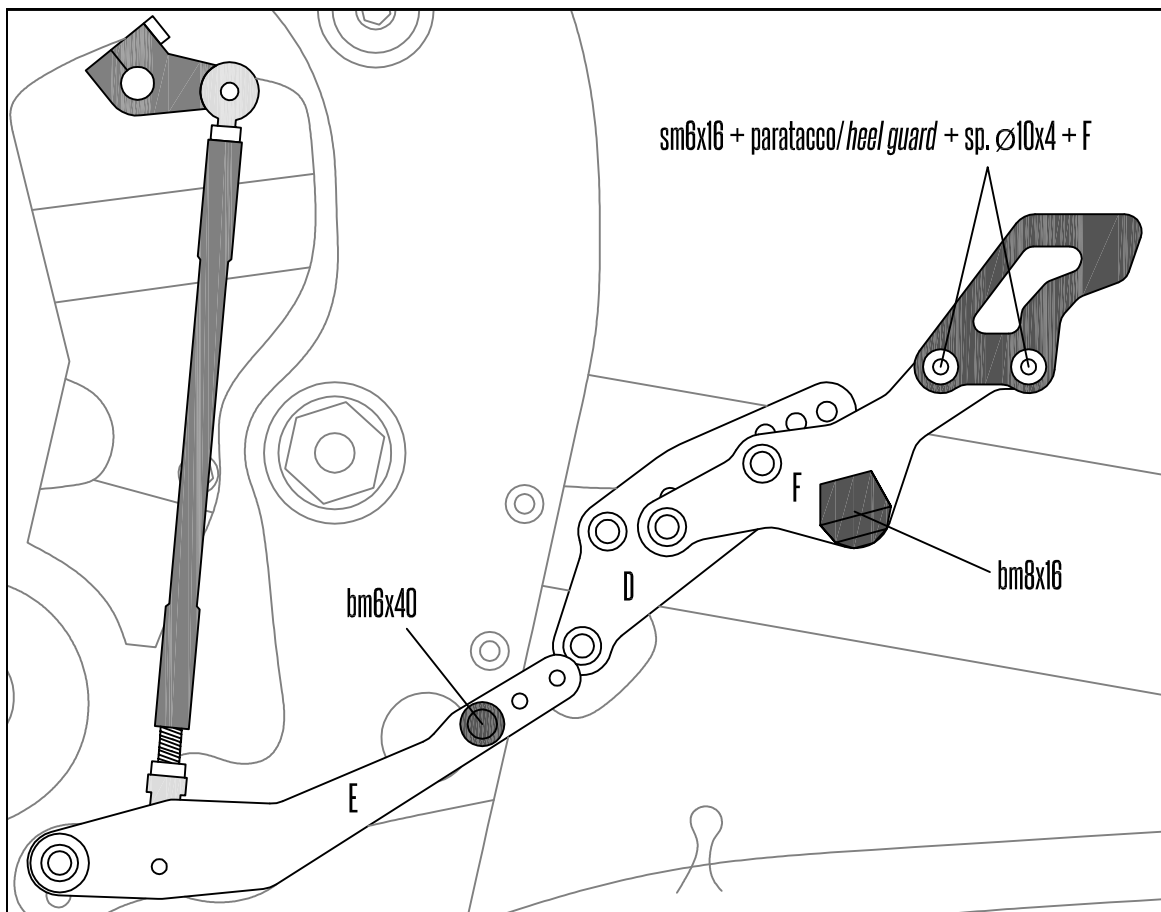

Cambio
rovesciato
Reverse
gear

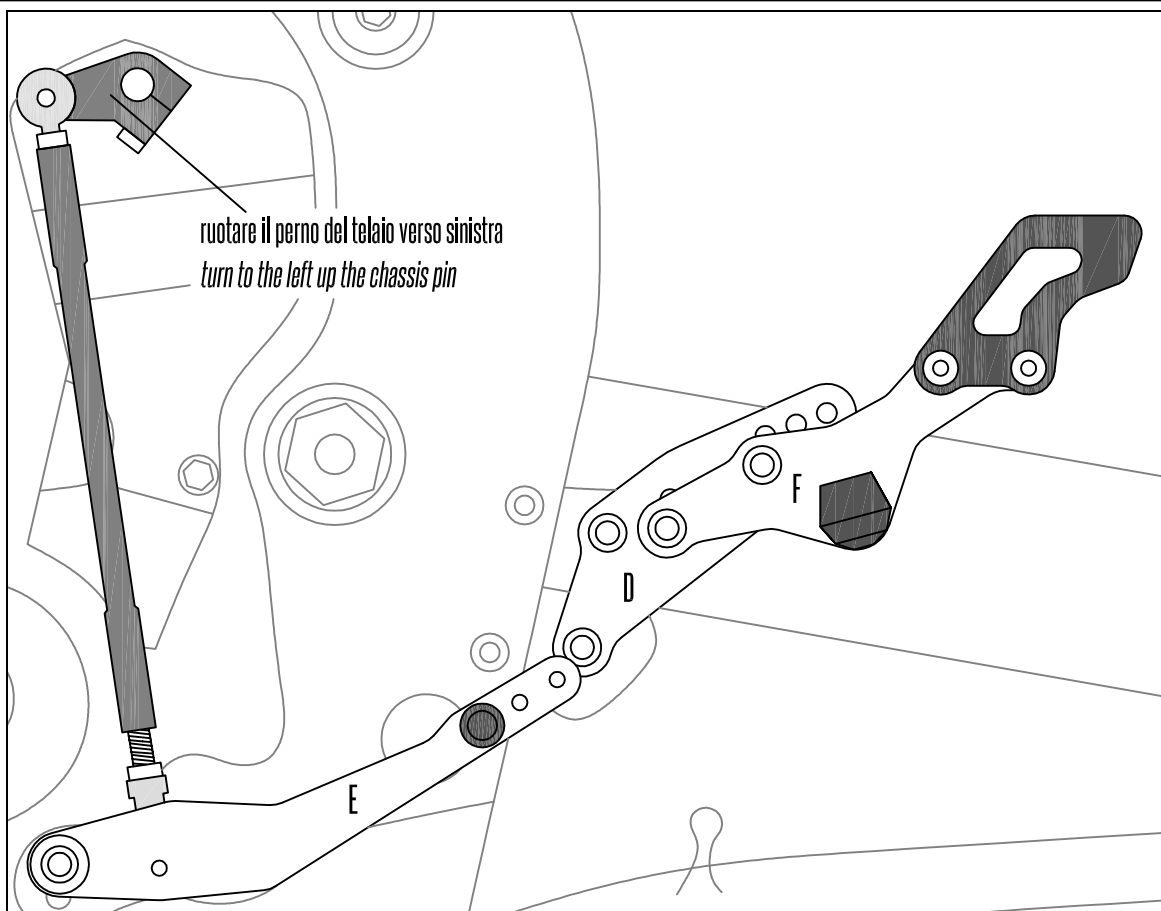

Suzuki Gsx-R 600 (2006-2010)

Idrostop

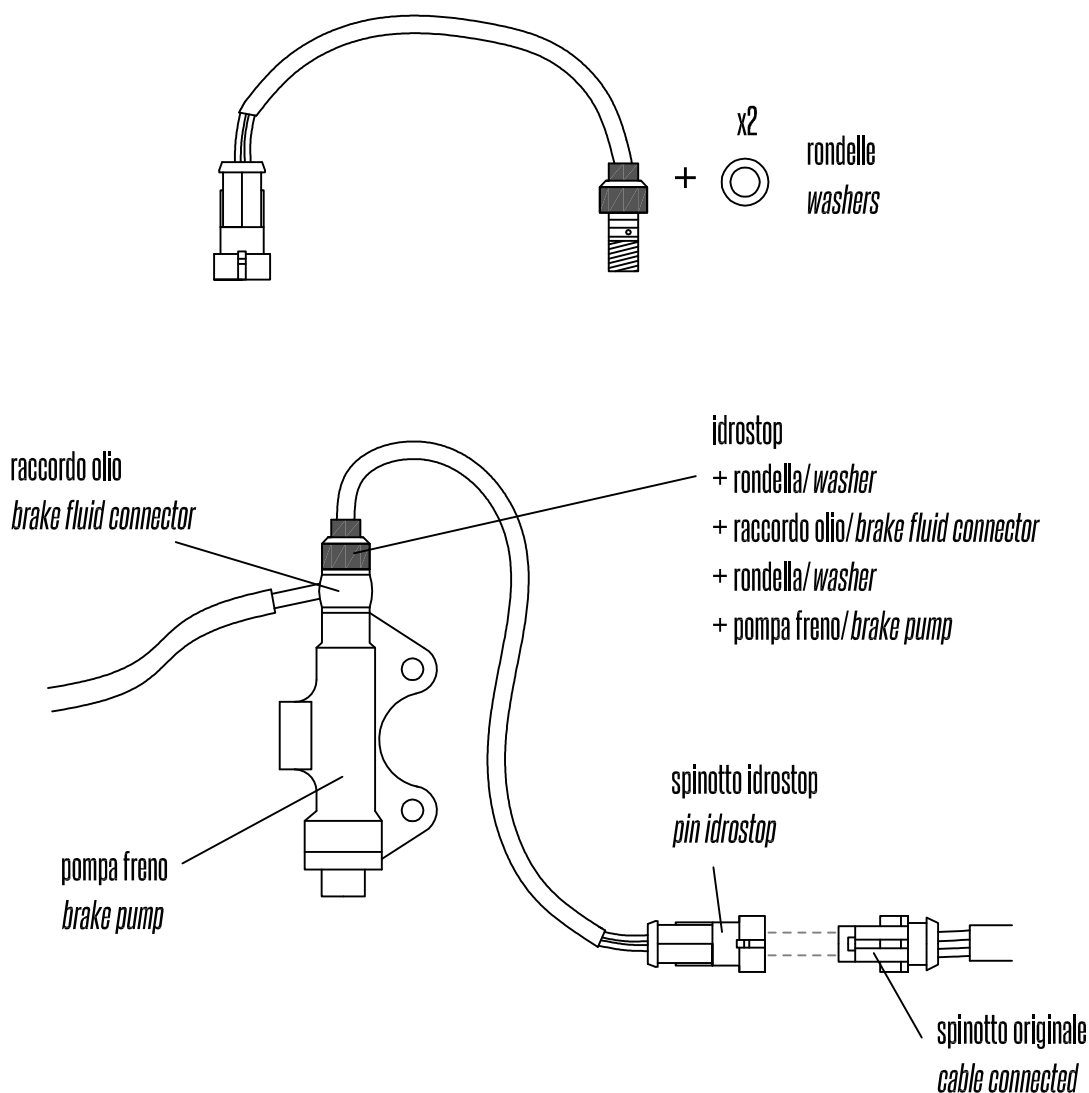

Su alcuni modelli di moto (es: Mt-07 e Hornet >2007) lo spinotto originale è diverso da quello descritto nell'immagine.

Su altri modelli invece il cavo può risultare corto e non permette il collegamento con lo spinotto.

In questi due casi è necessario cablare i fili con l'idrostop per poterlo collegare, oppure usare altri fili come prolunghe.

È consigliabile effettuare lo spurgo al termine del montaggio dell'idrostop, ma non è necessario se l'operazione viene effettuata correttamente.

For some models (ex: MT-07, Hornet>2007) the cable connected is different. In these case you need to cable the original one to connect on idrostop.

It's recommended to flush the brake fluid at the end of the idrostop mounting, but it's not necessary if the operation is successful.